

# 9/SVETSKI/BIJENALE/ STUDENTSKE/FOTOGRAFIJE



9<sup>TH</sup>/WORLD/BIENNIAL/OF  
/STUDENT PHOTOGRAPHY



3..2..1.. | ..1..2..3

ISO 100 1/80 F4.0

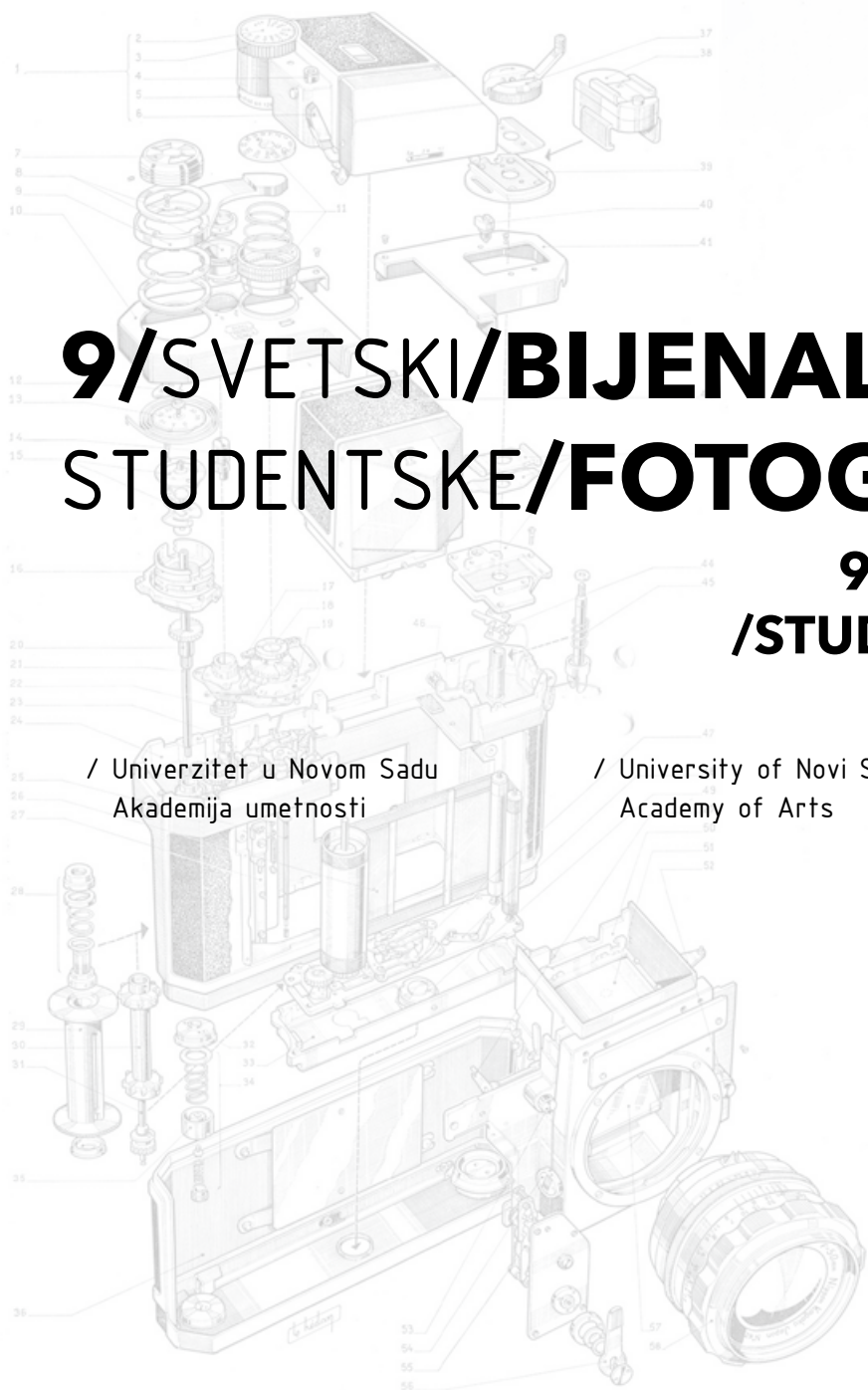
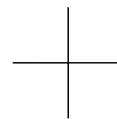

# 9/SVETSKI/BIJENALE/ STUDENTSKE/FOTOGRAFIJE

9<sup>TH</sup>/WORLD/BIENNIAL/OF  
/STUDENT PHOTOGRAPHY

/ Univerzitet u Novom Sadu  
Akademija umetnosti

/ University of Novi Sad  
Academy of Arts

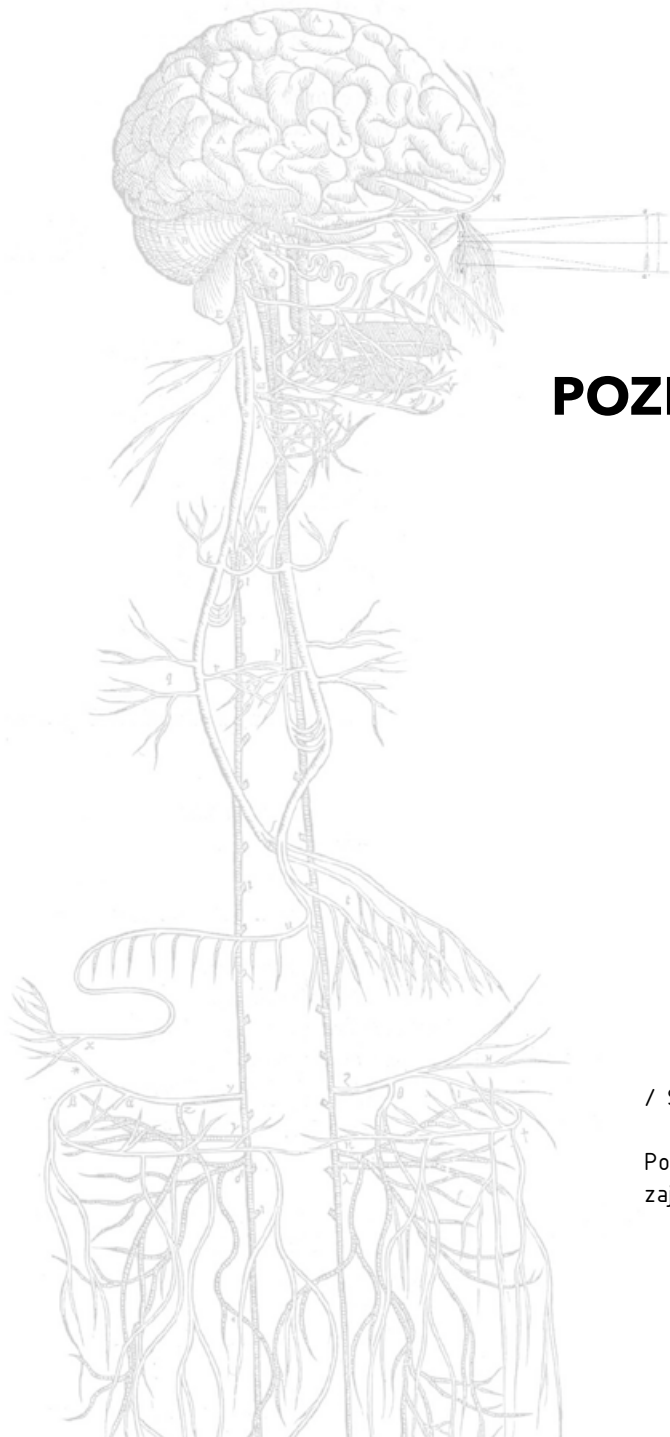
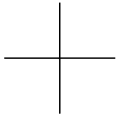

# POZDRAVNA REČ / INTRODUCTORY WORD

*/ Siniša Bokan, dekan Akademije umetnosti Novi Sad*

*/ Svetsko bijenale studentske fotografije podržali su:*

*Pokrajinski sekretarijat za kulturu, javno informisanje i odnose sa verskim zajednicama / Grad Novi Sad - Gradska uprava za kulturu / Minaqua / Optikus*

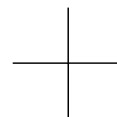

## BIJENALE OTVARA/EXHIBITION OPENING BY

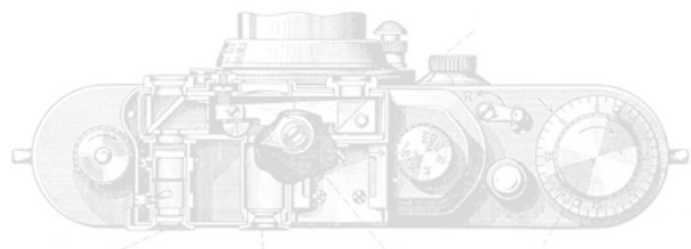

*/ Dragana Milošević, pokrajinski sekretar za kulturu,  
javno informisanje i odnos sa verskim zajednicama*

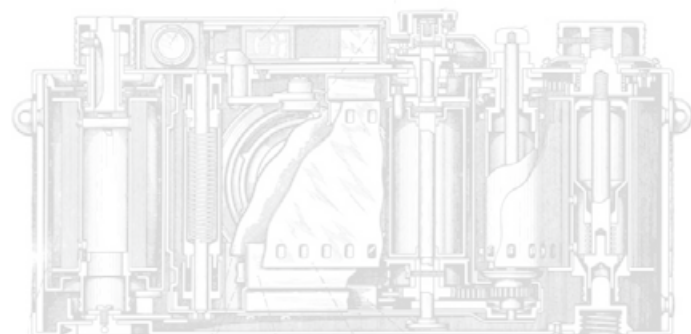

*/ The World Biennial of Student Photography was supported by:*

*Pokrajinski sekretarijat za kulturu, javno informisanje i odnose sa verskim  
zajednicama / Grad Novi Sad - Gradska uprava za kulturu / Minaqua / Optikus*

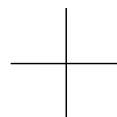

*Izdaje / Published by:*

Univerzitet u Novom Sadu, Akademija umetnosti / University of Novi Sad, Academy of arts & Vojvodina OK

*Glavni i odgovorni urednik / Editor in chief:*

prof. Siniša Bokan, dekan Akademije umetnosti / Dean of the Academy of Arts

*Urednik Izdanja / Editor:*

Ivan Karlavaris

*Direktor Bijenala / Manager of the Biennial:*

mr Ivana Tomanović, redovni profesor

*Likovni urednik / Art editor:*

Ivica Stevanović

*Grafički i foto dizajn / Graphic & photo design:*

Nikola Popović, Petar Stamenković (3D)

*Postavka bijenala / Exhibition setup:*

mr Ivana Tomanović, redovni profesor

*Kristalna plaketa / Crystal plaque:*

Petar Stamenković (3D)

*Konferansa na otvaranju Svetskog bijenala / The opening of the World Biennial of Student Photography hosted by:*

Adriana Salihović / Kristina Birčanin, klasa profesora Boris Liješević i samostalni stručni saradnik Milan Novaković

*Muzička numeracija / :*

"Four on the Floor" (ansambl saksofona) Mateja Blažić, sopran saksofon / Katarina Kostić, alt saksofon / Nikola Bošković, tenor saksofon / Antonela Ilijić, baritone saksofon, klasa Kristijan Boroš

*Tehnički urednik i priprema za štampu / Technical editor and prepress:*

Dragan Polovina

*Štampa i dorada / Print and binding:*

Simbol, Petrovaradin

*Tiraž / Circulation:*

750

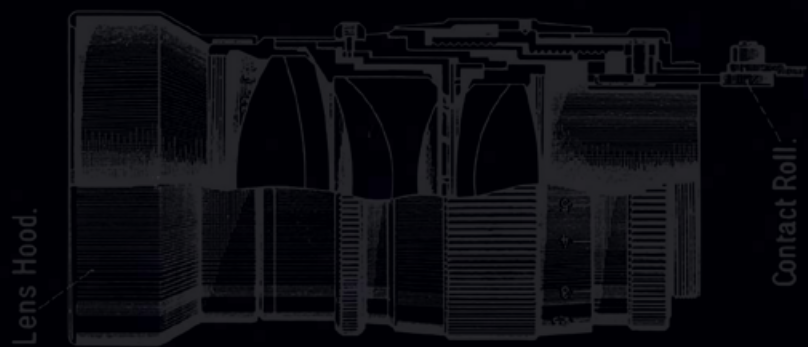

# ORGANIZACIONI ODBOR / ORGANISATION BOARD

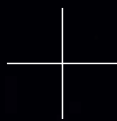

/ Ivana Tomanović, predsednik  
Boris Kočič  
Mitar Simikić



**DOBITNICI PRIZNANJA**  
**"KRISTALNA PLAKETA" / "CRYSTAL PLAQUETTE"**  
AWARD

/ Irina Subotić, 2009  
Nenad Ostojić, 2009  
Ivica Lukanović, 2014  
Ervin Dubrović, 2014  
Akademija umjetnosti Univerziteta u Banjoj Luci, 2014  
Branimir Karanović, 2015  
Ivan Karlavaris, 2017  
Branislav Dobanovački, 2017

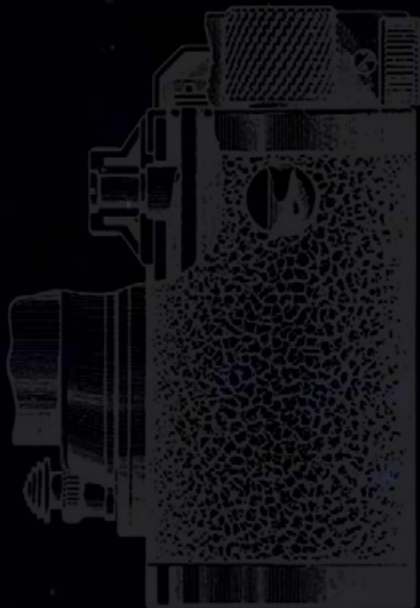



**OSNIVAČI BIJENALA** / FOUNDERS OF THE BIENNIAL

/ Ivan Karlavaris  
Branislav Dobanovački



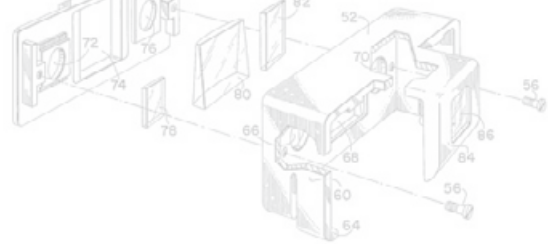

## SVETSKI BIJENALE STUDENTSKE FOTOGRAFIJE 2023. /

WORLD BIENNIAL OF STUDENT PHOTOGRAPHY 2023

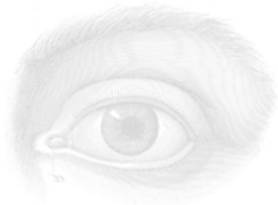

/ Akademija umetnosti Novi Sad svake druge godine realizuje *Svetksi bijenale studentske fotografije*, manifestaciju koja je odlična promocija fotografske umetnosti i prakse kao medija koji se izučava u okviru visokoškolskih institucija širom sveta.

Tako i ove godine Novi Sad postaje centar studentske fotografije na međunarodnom nivou, uz obilje prispelih radova različitih vidova fotografskog izraza. Međunarodni žiri ima zadatak da odabere najbolje od prispelih radova, ali i da svedoči neprestanim inovacijama u prostoru medija fotografije. Imajući u vidu tehnološka dostignuća i nove mogućnosti umetničke komunikacije, izvesno je da se manifestacija *Svetksi bijenale studentske fotografije* konstantno unapređuje u svakom smislu, promocijom novih stvaralaca, prezentacijom aktuelnih fotografskih praksi, dostignućima edukativnih kreativnih procesa i uvidom u mogućnosti novih tehnologija. Obilje informacija i impresija koje pruža Bijenale, sigurno je već potpuno generički projekat koji Akademija umetnosti uspešno realizuje dugi niz godina.

Bijenale afirmiše mlade stvaraoce, stvara temelj za pojavu novih generacija, dokazujući da se prostor fotografskog medija uvek iznova aktualizuje bez obzira na vreme i tehnologije

/ Siniša Bokan  
Novembar 2023.

## **WORLD BIENNIAL OF STUDENT PHOTOGRAPHY 2023 /** SVETSKI BIJENALE STUDENTSKE FOTOGRAFIJE 2023.

/ The Academy of Arts Novi Sad organizes the World Biennial of Student Photography every second year, an event which serves as an excellent promotion of the photography art and practice as a medium which is studied within higher education institutions around the world.

This year again, Novi Sad is becoming the centre of student photography at the international level, with the abundance of submitted works of various types of photography. The international jury has the task of selecting the best of the submitted works, but they also witness continuous innovations in the area of the photography medium. Bearing in mind technological achievements and new possibilities of artistic communication, it is certain that the event of the World Biennial of Student Photography is constantly improving in every sense by promoting new creators, presenting current practices in photography, achievements in educational creative processes and insight into the possibilities of new technologies. The abundance of information and impressions provided by the Biennial has certainly already made it a completely generic project that the Academy of Arts has been successfully implementing for many years.

The Biennial has been promoting young creators, creating a foundation for the emergence of new generations, proving that the space of the photography medium is constantly being updated, regardless of the time and technology.



/ Siniša Bokan  
*dekan Akademije umetnosti  
Novi Sad*

/ Siniša Bokan  
*November 2023*

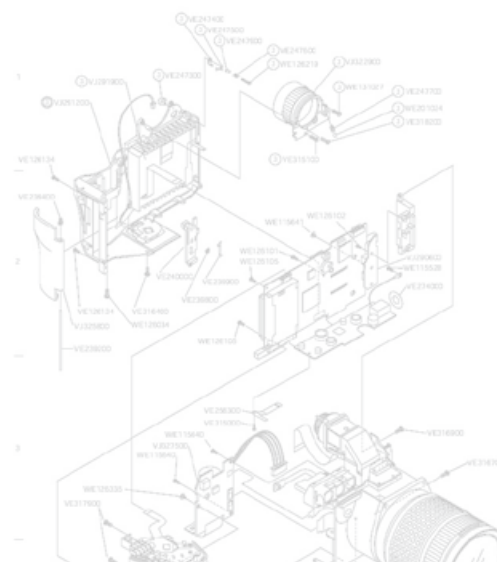



## ŠTA NAM GOVORE FOTOGRAFIJE? /

## WHAT ARE THE PHOTOGRAPHS TELLING US?

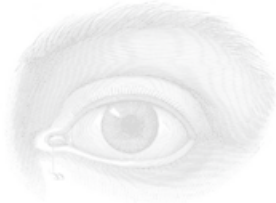

/ U vreme sveopšte ekspanzije fotografije, sve manje se pitamo da li je neka fotografija „dobra“ ili „loša“. Ova dva prideva uglavnom označavaju tehničku prirodu fotografije, tj. da li je fotografija snimljena dobro ili ne. Suštinski, nema potrebe to više da se pitamo jer su, danas, skoro sve fotografije dobro snimljene. Takva situacija ostavlja nam dovoljno prostora da razmišljamo o tome šta nam to fotografije govore, o čemu se zapravo radi na mnogobrojnim fotografskim prizorima kojima smo izloženi svakodnevno i u velikim količinama. A biti originalan, ili bolje reći autentičan, u svetu masovne produkcije slika nije jednostavno.

Naše Bijenale nosi dva prefiksa – svetsko i studentsko. Oba nose odrednicu koja određuje karakter Bijenala. Ono je „šaroliko“ i uzbudljivo jer nam donosi varijetet različitih kultura, vizura, običaja, karaktera... Povrh svega ono objedinjuje klasičnu (analognu) i digitalnu fotografiju, dokumentarizam i kolaž, pojedinačnu fotografiju i seriju, koncept i žanrovsku fotografiju... Polemika oko svrsishodnosti studiranja fotografije danas i dalje se vodi jer stiče se utisak da je znanje dostupno svima. I da, znanje jeste dostupno svima nama, ukoliko znamo da ga klasifikujemo, vrednujemo, povežemo i upotrebimo. E tu se stvari malo komplikuju, rekla bih malo više, jer je upravo to mnoštvo znanja i informacija, i blagodeć i zamka. Visoke stručne škole imaju svoju strukturu, vremensku odrednicu, tehničke uslove, kolektivni duh i konačno, evaluaciju. Sve to omogućava istovremeno duboko i široko gledanje na medij fotografije koje rezultira specifičnim, i neretko autentičnim izrazima unutar dvodimenzionalnog polja fotografije koje, poslednjih godina sve više i sve bolje polemische nad svojom plošnošću, osvajajući trodimenzionalni prostor, kako stvarni tako i virtuelni.

Tehnološke, pa samim tim i kreativne mogućnosti postale su nepregledne i nesagledive, menjajući se iz dana u dan što čini „trku“ teškom, a verujem i zamornom. To je izazov s kojim se mladi ljudi danas suočavaju pa je svaka pomoć, lična ili institucionalna, dobro došla.

Akademija umetnosti, kao institucija od velikog i dugogodišnjeg značaja za kulturu i umetnost u Novom Sadu i regionu, po deveti put animira institucije širom sveta i njihove studente da pod okriljem konkursa Svetskog bijenala studentske fotografije pokažu neke od trenutnih tendencija u razmišljanju mladih ljudi, koje ih to teme interesuju, muče ili vesele, kako vide i razumeju medij fotografije i koliko je to sve razumljivo i zanimljivo – nama auditorijumu.

Taj zadatak nije nimalo lak jer nam radovi dolaze sa svih pet kontinenata. A za nas s Akademije umetnosti ovo je prilika i da malo „odmerimo snage“, tj. da vidimo gde smo mi u odnosu na druge, da li smo staromodni, klasični ili progresivni, da li smo drugačiji ili se uklapamo u opšti trend, da li naši kulturološki, socijalni i ekonomski uslovi diktiraju neku specifičnost ili su društvene mreže i slobodan protok slika učinili da smo zaista jedno globalno selo u kom svi mislimo o istim temama i na sličan način.

Verujem i da širu umetničku zajednicu muče ista ova pitanja, a nema drugog načina da to saznamo do na izložbi odabranih i nagrađenih radova 9. Svetskog bijenala studentske fotografije 2023. u Novom Sadu.

/ Ivana Tomanović  
Novembar 2023.

## WHAT ARE THE PHOTOGRAPHS TELLING US? / ŠTA NAM GOVORE FOTOGRAFIJE?

/ In the time of general expansion of photography, the question whether a photograph is “good” or “bad” is becoming less relevant. These two adjectives mostly refer to the technical nature of photography, i.e. whether the photograph was taken well or not. Essentially, there is no need to pose this question because, today almost all photographs are taken well. Such a situation allows us to think more about what the photographs are telling us, what the numerous photography scenes that we are exposed to every day and in large quantities are actually about. And being original, or rather, authentic, is certainly not easy in the world of image mass production.

Our Biennial has two prefixes – world and student. Both of them refer to a key feature that determines its character. It is “colorful” and exciting because it brings a variety of different cultures, views, customs, characters... Above all, it combines classic (analog) and digital photography, documentary and collage, individual photography and series, concept and genre photography... Controversy about the expediency of studying photography continues even today because there is an impression that this knowledge is available to everyone. And yes, the knowledge is available to all of us, if we know how to classify, evaluate, connect and use it. This is where things get a little more complicated, or a lot more complicated, I would say, because this abundance of knowledge and information can be both a blessing and a curse. Vocational schools have their own structure, time frame, technical requirements, collective spirit and finally, evaluation practice. All this enables a simultaneously deep and broad perspective of the photography medium, resulting in specific, and often authentic expressions within the two-dimensional field of photography, which has, in recent years, been followed by more frequent and substantial arguments on its flatness, conquering the three-dimensional space, both real and virtual.

Technological and therefore creative possibilities have become limitless and unfathomable, as they change every day, making the “race” difficult and, I believe, tiring. This is a challenge young people are facing today; therefore, any kind of help, whether personal or institutional, is welcome.

The Academy of Arts, as an institution of great and long-standing importance for culture and art in Novi Sad and the region encourages the institutions and students around the world through the World Biennial of Student Photography Call to present some of the current tendencies in how young people today think, what topics interest, trouble or excite them, how they see and understand the medium of photography and how we – the audience – understand it and what we find interesting.

This task is not easy at all because we receive the works from all five continents. And for us from the Academy of Arts, this is an opportunity to “measure our strengths” a little, i.e. to see where we stand in relation to others; whether we are old-fashioned, traditional or progressive; whether we are different or we fit into the general trend; whether cultural, social and economic conditions dictate some specific features or whether social networks and the free flow of images really made us a part of one global village where we all refer to the same topics in a similar way.

I also believe that the broader art community is troubled by the same questions, and there is no other way to investigate them but to visit the exhibition of the selected and awarded works of the 9th World Biennial of Student Photography 2023 in Novi Sad.



/ Ivana Tomanović  
red. prof.

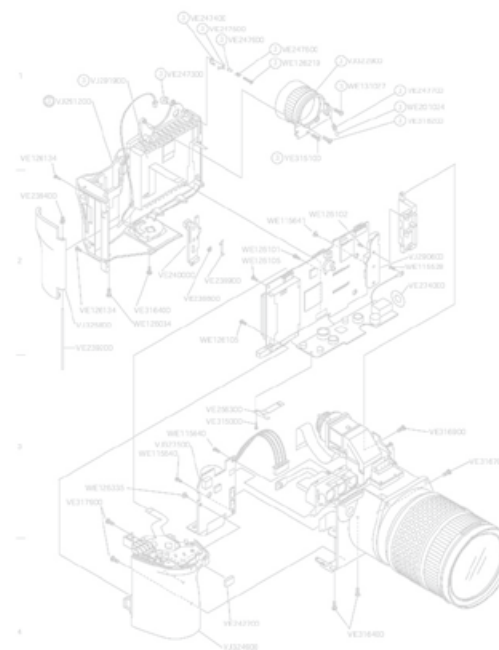

/ Ivana Tomanović  
*November 2023*

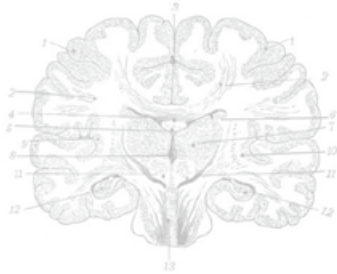
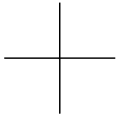

3..2..1.. | ..1..2..3

## **NAGRADE**/PRIZES

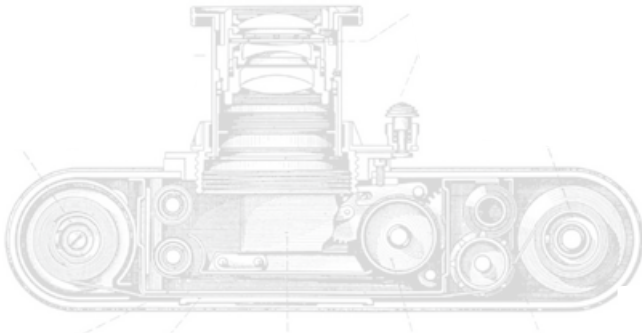

1<sup>st</sup> prize / Mouneb Taim  
2<sup>nd</sup> prize / Daria Litvishko  
3<sup>rd</sup> prize / Jahid Apu

## **PRIZNANJA**/HONORABLE MENTIONS

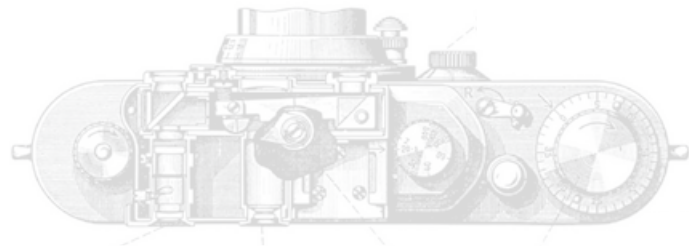

/ Julian Cabral  
Ionna Spentzou

*Special prize* awarded by non-government organization "Vojvodina OK"  
for the best student project in the national category:

/ Vladimir Janić

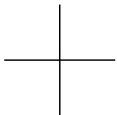
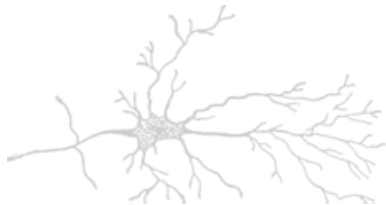

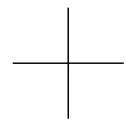

/ Evangelia Katsaiti  
/ Greece



Mitar Simikić /  
/ Serbia



/ Borislav Božić  
/ Croatia



Vladimir Tatarević /  
/ Serbia



/ Bertan Selim  
/ Netherlands

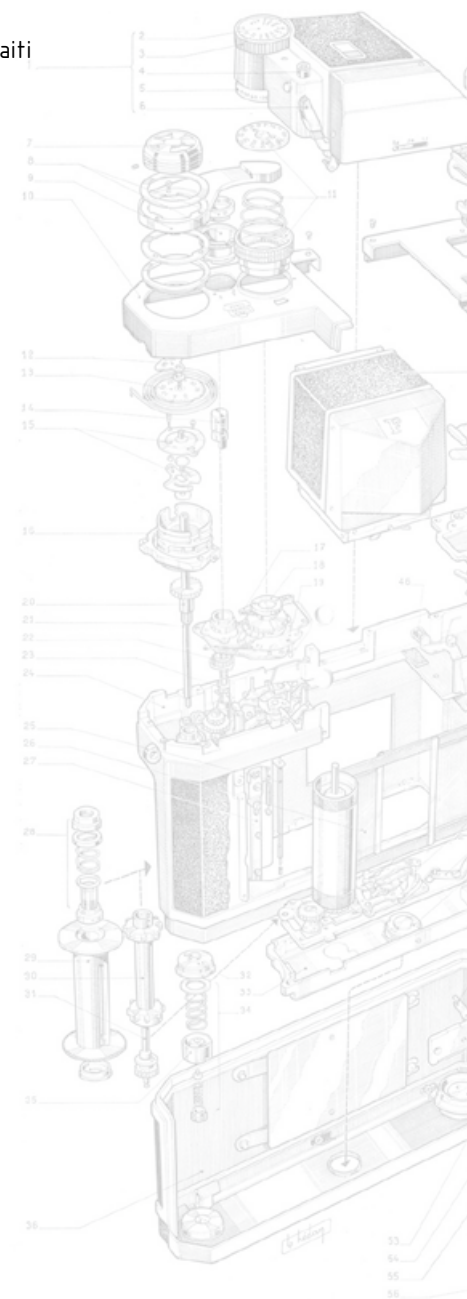

# ŽIRI / JURY

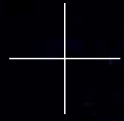
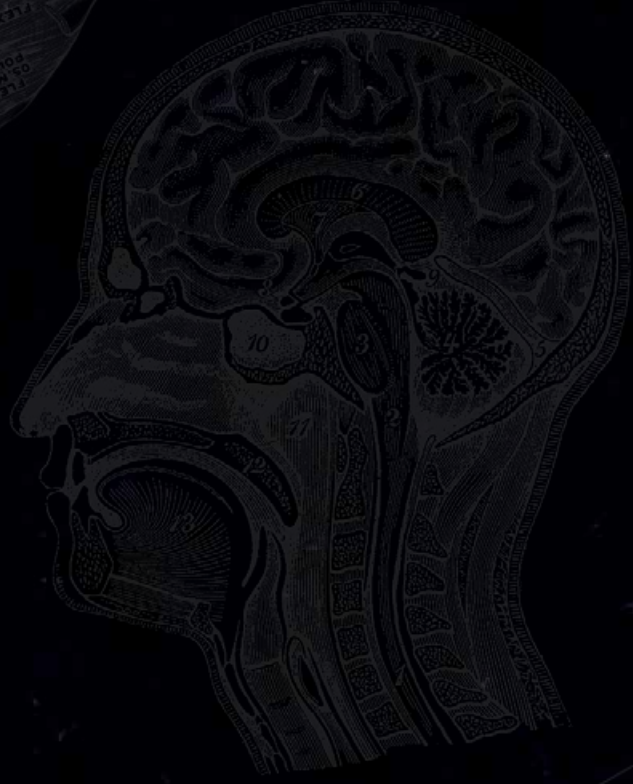

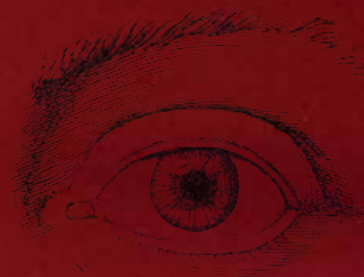
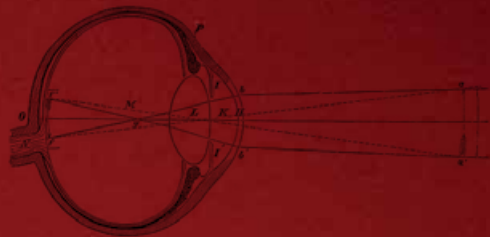

# UČESNICI/PARTICIPANTS

ISO 100 1/80 F4.0

3..2..1.. | ..1..2..3

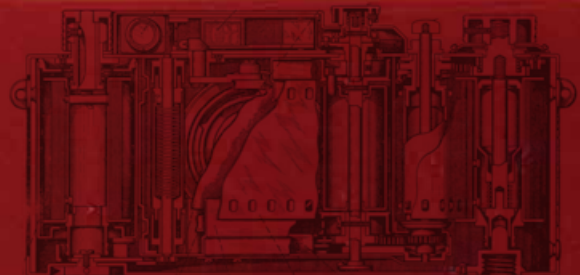
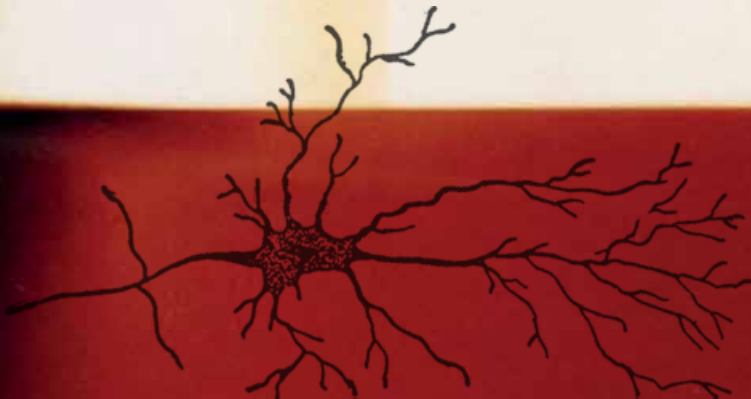





ISO 100 1/80 F4.0

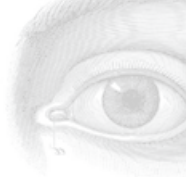

University of West Attica / *Paranormal*

3..2..1.. | ..1..2..3

GREECE / **AIKATERINI DELIGIANNI**

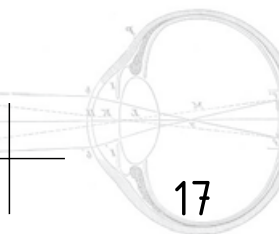



Academy of Fine Arts Sarajevo / *Urban Illusions*



ISO 100 1/80 F4.0



**AJLA BALIJAGIĆ** / BOSNIA & HERZEGOVINA

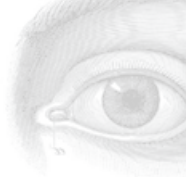

Academy of Arts, University of Novi Sad / *Glimpse of the ocean*



3..2..1.. | ..1..2..3

SERBIA / **ALEKSANDRA NOVAKOVIĆ**

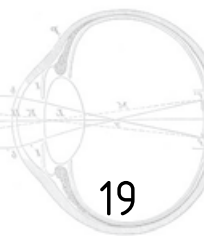

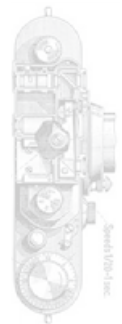

Academy of Arts, University of Novi Sad / A Blacksmith's Tale



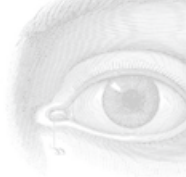

MYPH / Search



3..2..1.. | ..1..2..3

UKRAINE / **ALENA BURYA**

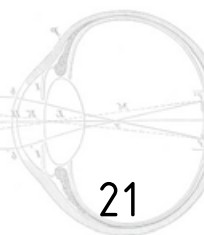



The New School, Brooklyn / Protecting my peace



**ALESSANDRO SECCARECCIA** / UNITED STATES

ISO 100 1/80 F4.0



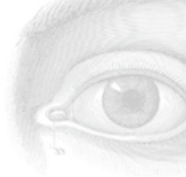

DocDocDoc school of modern photography / *Alive, dead, chaotic*



3..2..1.. | ..1..2..3

RUSSIA / **ALEXANDRA KHLEBNIKOVA**

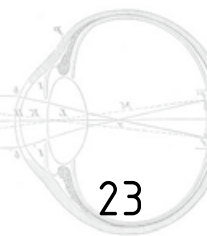



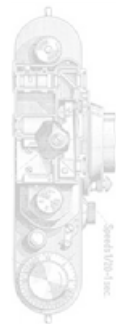

Academy of Fine Arts Sarajevo / Emotional perception of value



**ALISA KRESO** / BOSNIA & HERZEGOVINA

ISO 100 1/80 F4.0



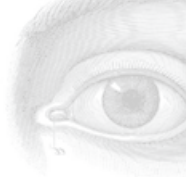

Academy of Fine Arts Sarajevo / *Life and work of Shigi-san*



3..2..1.. | ..1..2..3

BOSNIA & HERZEGOVINA / **ANA DUTINA**





Faculty of Technical Sciences, University of Novi Sad /  
*Photographic Portrait of Pivnice Village*



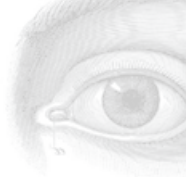

Faculty of Applied Arts Belgrade / In search for the unseen

3..2..1.. | ..1..2..3

SERBIA / ANA PETROVIĆ

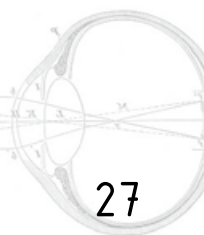



University of West Attica / Lernaean Hydra

**ANARGYROS DROLAPAS / GREECE**

ISO 100 1/80 F4.0



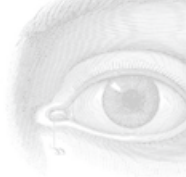

МЯПН / *My life in a white frame*



3..2..1.. | ..1..2..3

UKRAINE / **ANASTASIIA DEKHTIARUK**

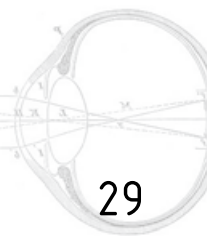



University of Nicosia / *Untitled*



ISO 100 1/80 F4.0



**ANGIE VEIN / CYPRUS**

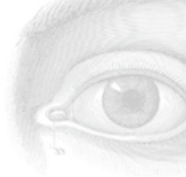

Academy of Arts, University of Novi Sad / *Untitled*

3..2..1.. | ..1..2..3

SERBIA / **ANJA JURCA**

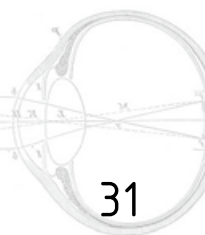





Academy of Fine Arts Sarajevo / *Untitled*

**ANJA STERGAR** / BOSNIA & HERZEGOVINA

ISO 100 1/80 F4.0



9<sup>TH</sup>/WORLD/BIENNIAL/OF/STUDENT PHOTOGRAPHY

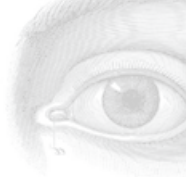

ММФ / *Observing Irreversibility*

3..2..1.. | ..1..2..3

UKRAINE / ANNA ZHUKOVA

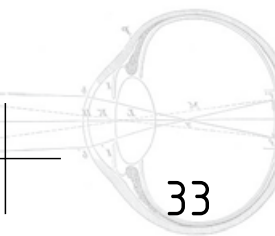



Hochschule Hannover / Untitled

**AREZ GHADERI / GERMANY**

ISO 100 1/80 F4.0



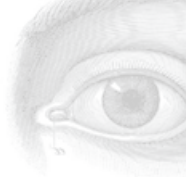

Hochschule Hannover / Najib



GERMANY / **ARMINA (NEDA) AHMADINIA**

3..2..1.. | ..1..2..3

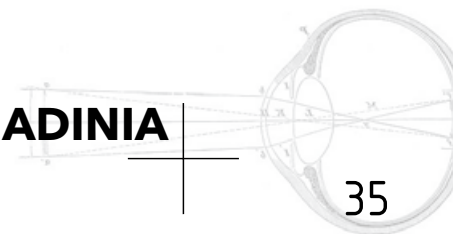

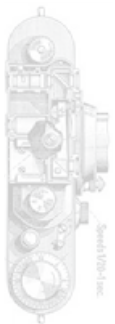

*MYPH / Awakening amidst reality and dreamscapes*



ISO 100 1/80 F4.0



**ARTEM HONCHARIUK / UKRAINE**



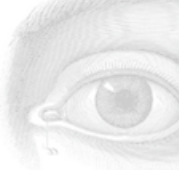

University of West Attica / *Peace of Mind*

GREECE / **ATHINA TEKTONIDOU**

3..2..1.. | ..1..2..3

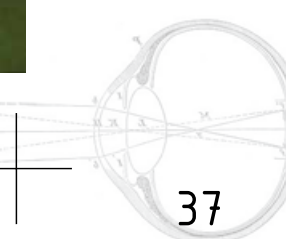



Florida Atlantic University / Search for a meaning – Transformation



**AZARAKHSH SHAFIEIKADKANI / UNITED STATES**

ISO 100 1/80 F4.0



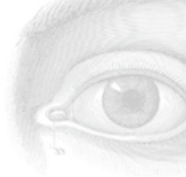

Fulbright University Vietnam / Kha Binh - Quite Cool



3..2..1.. | ..1..2..3

VIETNAM / **BEN-BÙI NGUYEN**





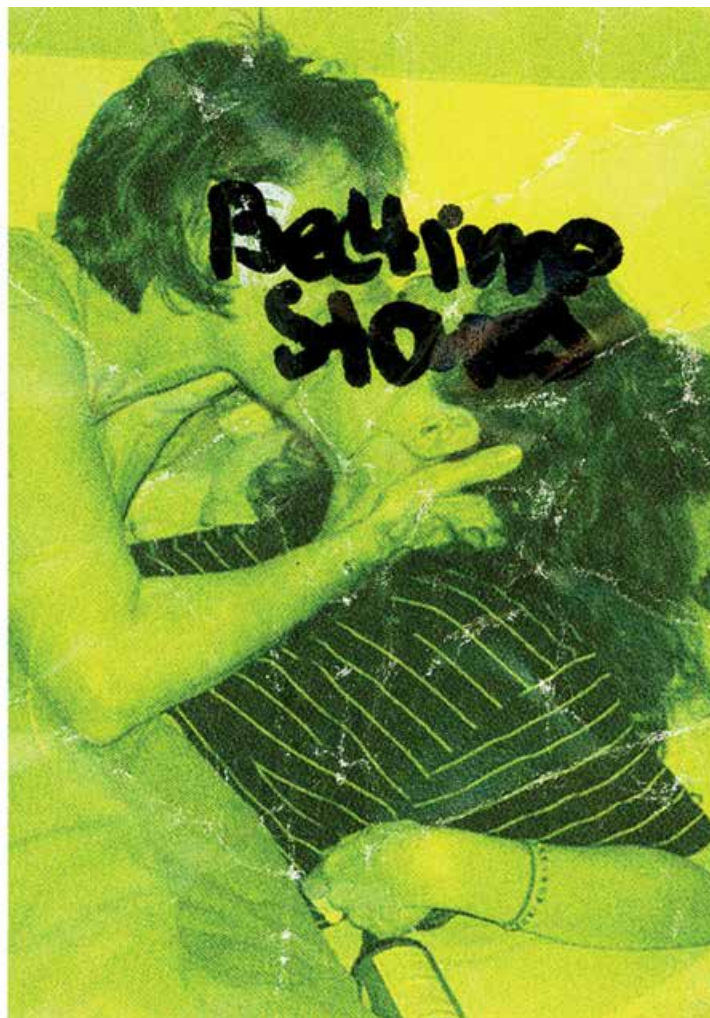
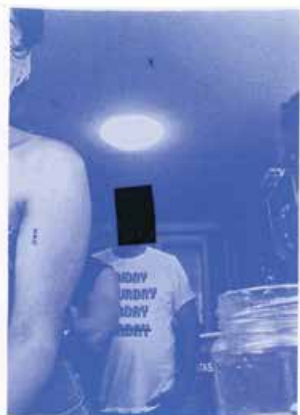
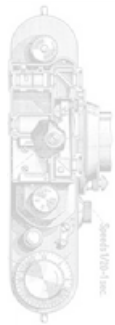

I made these shitty prints for you

**BIANKA ÉZSÖL** / SLOVAKIA

ISO 100 1/80 F4.0



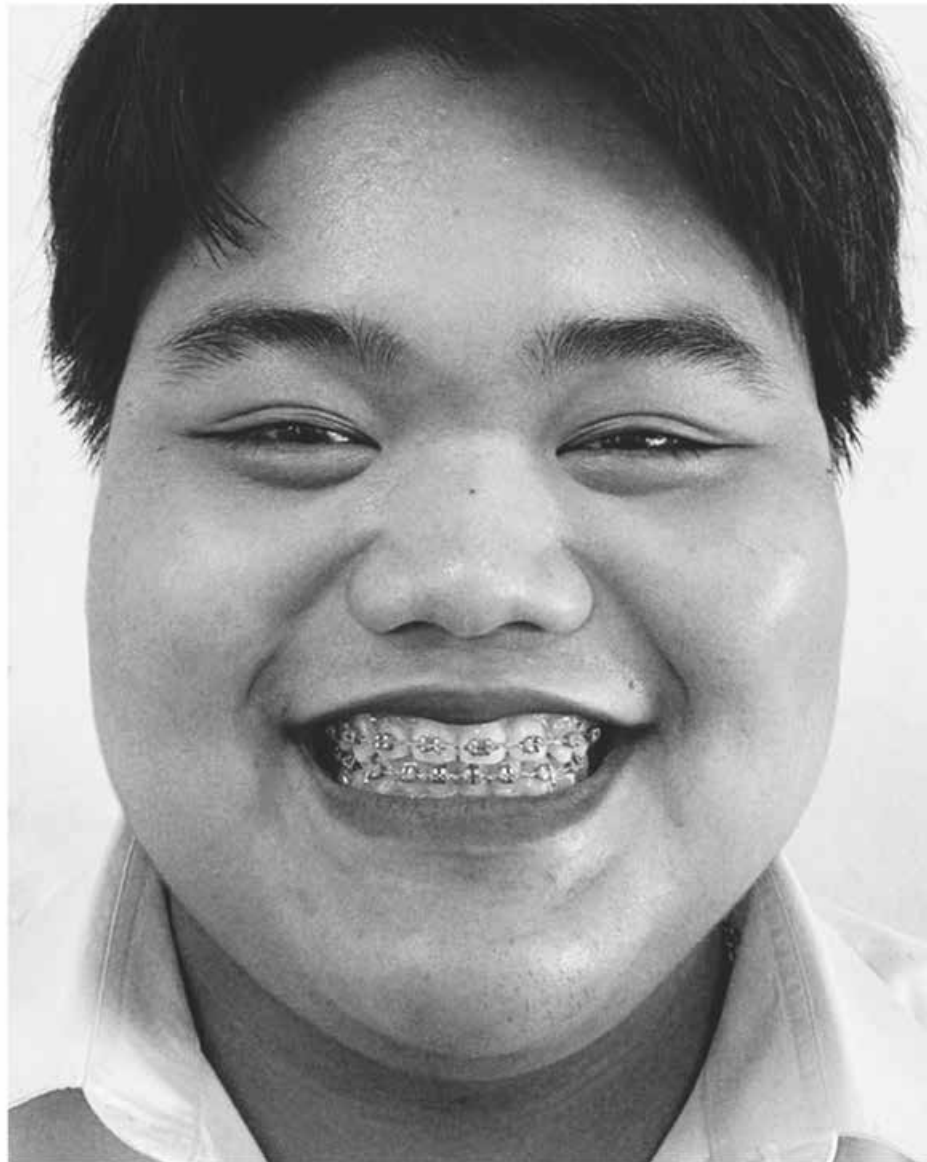
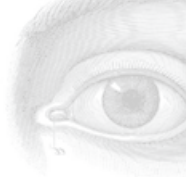

Dhurakij Pundit University / Student

3..2..1.. | ..1..2..3



THAILAND / **CHENG YIZE**

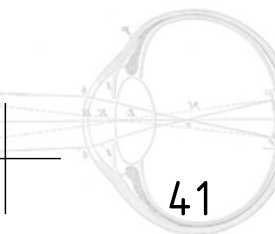



University of West Attica / Traces

**CHRISTINA MICHOU / GREECE**

ISO 100 1/80 F4.0



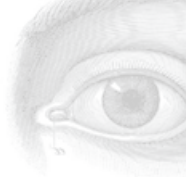

Fotoacademie Amsterdam / *Body*

NETHERLANDS / **CONSTANCE KONINGSBERGER**

3..2..1.. | ..1..2..3

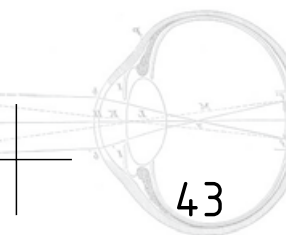



University of west Timisoara, Faculty of arts and design / *Roots*



**CĂTĂLINA JOIȚA** / ROMANIA

ISO 100 1/80 F4.0



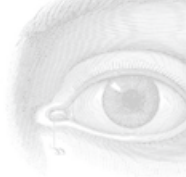

DocDocDoc school of modern photography / Black sea



3..2..1.. | ..1..2..3

RUSSIA / **DARIA LITVISHKO**

**2<sup>ND</sup>** PRIZE

45





*/ The Country*

**DIANA DZHAMBULOVA / RUSSIA**

ISO 100 1/80 F4.0



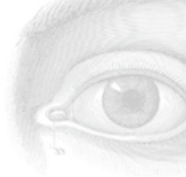

DocDocDoc school of modern photography / Eyes the color of sea water



3..2..1.. | ..1..2..3

RUSSIA / **DMITRY KAVERIN**





University Of Guadalajara / Loneliness in the mountains



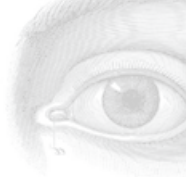

University of West Attica / Nighthawks



3..2..1.. | ..1..2..3

GREECE / EFTHIMIA ATHANASIOU

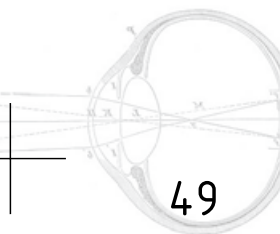

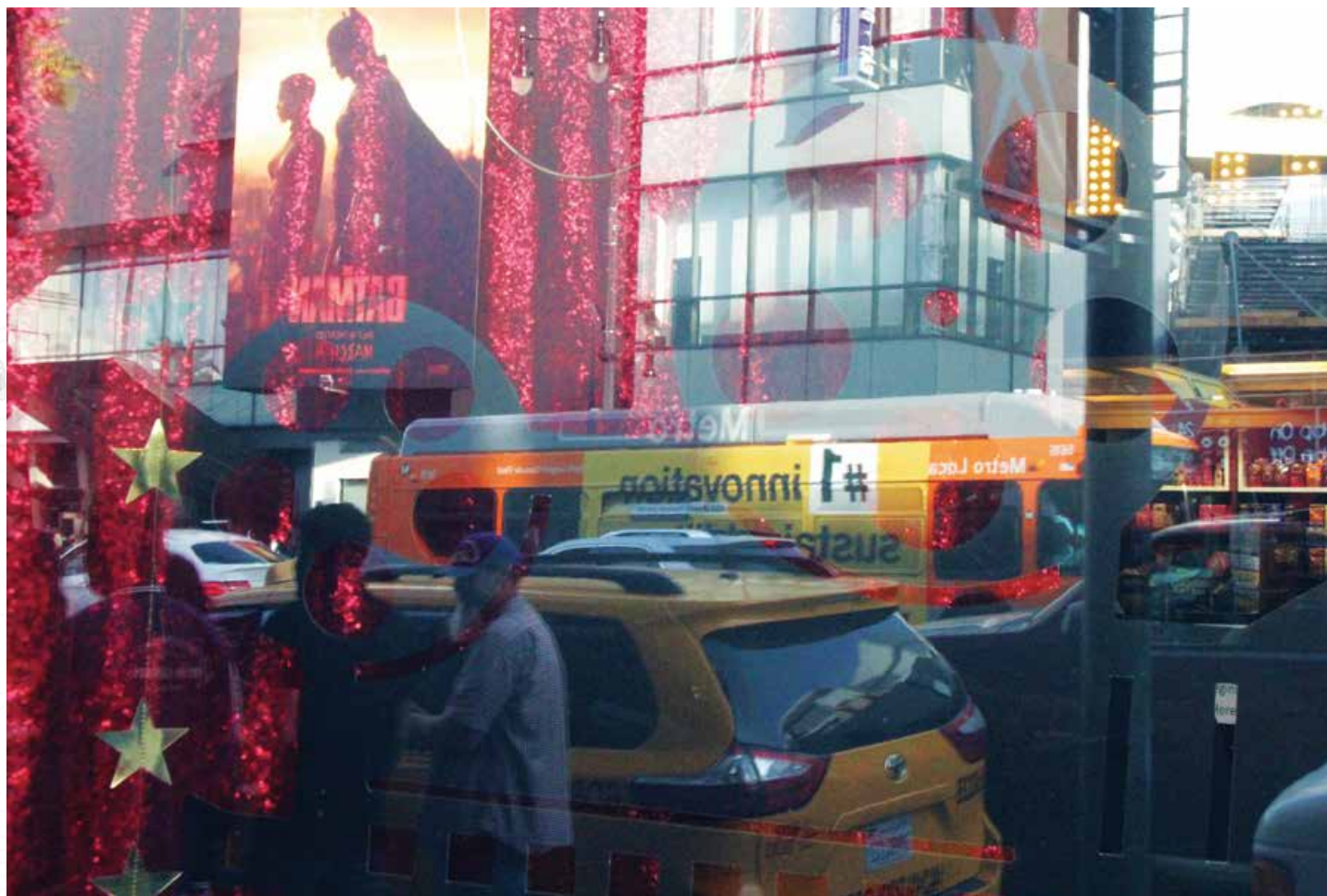

Artcenter College of Design / *Untitled*

**ELEANOR YANG** / CHINA

ISO 100 1/80 F4.0



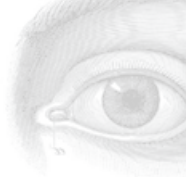

DocuDoc school of modern photography / Red Man



3..2..1.. | ..1..2..3

BELARUS / **ELENA DONBROVA**





Marmara University Faculty of Fine Arts / Supernova

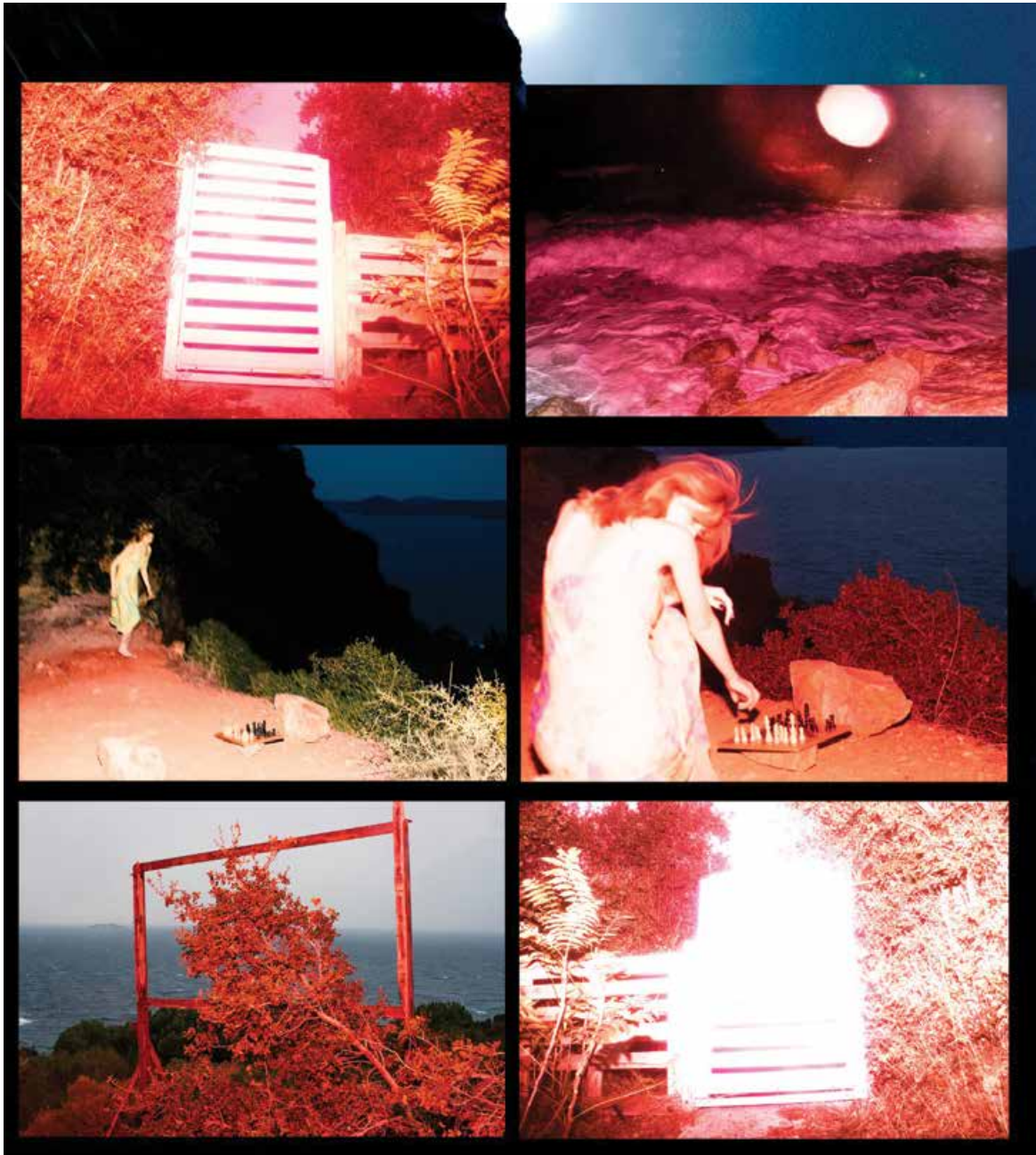

ISO 100 1/80 F4.0



**ELIF UZUN / TURKEY**

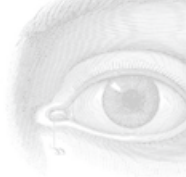

Academy of Arts, University of Novi Sad / *Evanidus* - Photographic Installation

3..2..1.. | ..1..2..3

SERBIA / **EMILIJA SANDIĆ**



University of West Attica / *Unfamiliarly Familiar*

**EMMA GKAMPARIAN** / GREECE

ISO 100 1/80 F4.0



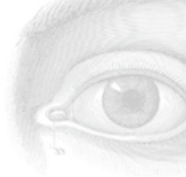

Université Paris 8 / *Untitled*

3..2..1.. | ..1..2..3

FRANCE / **ERIK SEMASHKIN**

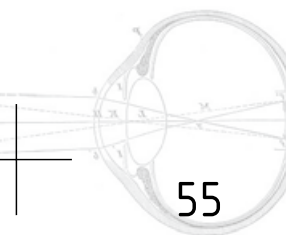





Academy of Fine Arts Vienna / *Heavy Mental*



ISO 100 1/80 F4.0



**ESTHER VÖRÖSMARTY / AUSTRIA**

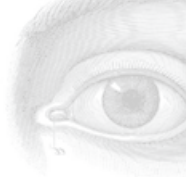

MYPH / Where are you?

3..2..1.. | ..1..2..3



UKRAINE / **EVA HOLTS**

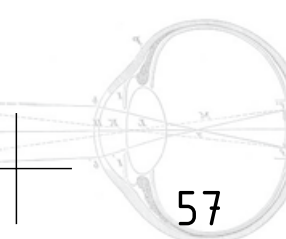

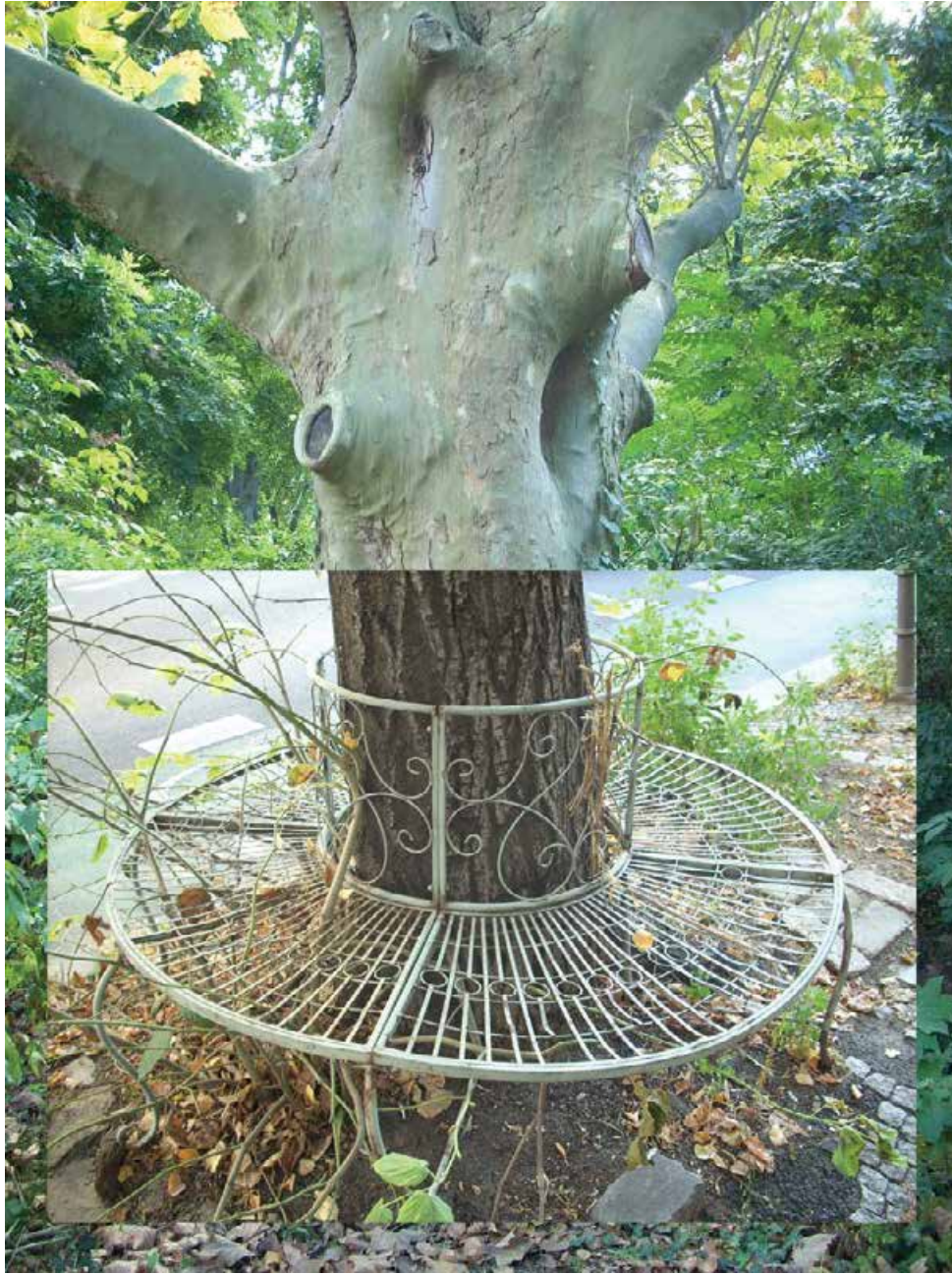

ISO 100 1/80 F4.0



University of Zagreb, Faculty of Architecture / September

**GABRIJELA KLARIN / CROATIA**

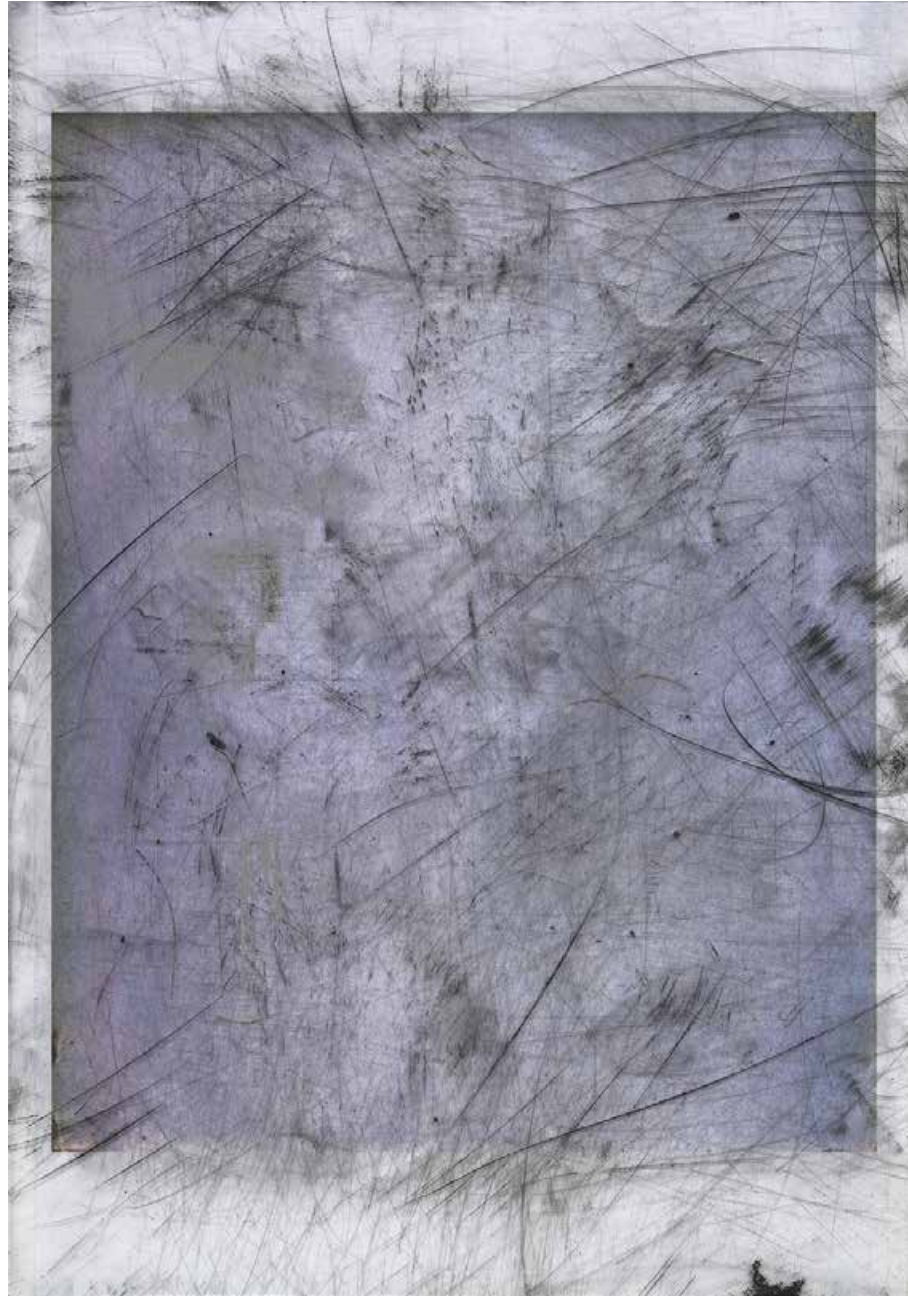
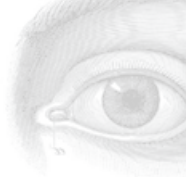

Parsons School of Design, Brooklyn / *Photography as Drawing*

3..2..1.. | ..1..2..3

UNITED STATES / **GUY GRABOWSKY**

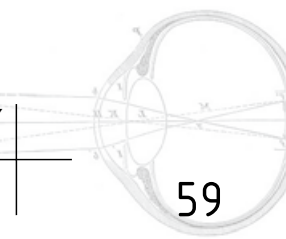

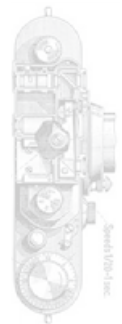

/ Untitled

**HUAN YAN / CHINA**

ISO 100 1/80 F4.0



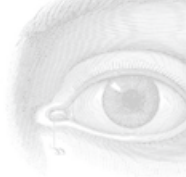

DocDocDoc school of modern photography / Abuse of power



3..2..1.. | ..1..2..3

RUSSIA / **IGOR SKABELIN**

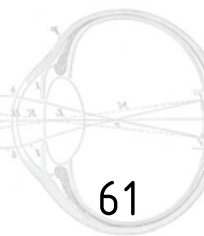



University of West Attica / Absentia

**IOANNA SPENTZOU / GREECE**

Honorable Mention

ISO 100 1/80 F4.0



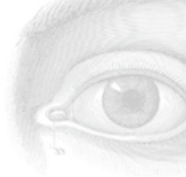

IT University / Soanierahana

3..2..1.. | ..1..2..3

MADAGASCAR / **IRIANTSOA RASOLONDALAO**

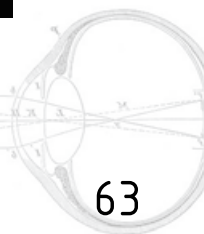





Academy of Arts, University of Novi Sad / *Hunger Games*



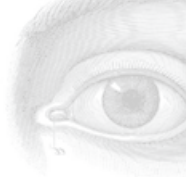

Alliance Française De Dhaka / *The Unchained Bird*



3..2..1.. | ..1..2..3

BANGLADESH / **JAHID APU**

**3<sup>RD</sup>** PRIZE

65

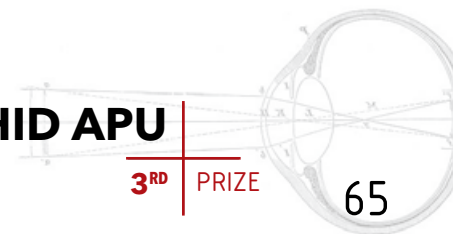



*/ Red Circle, Dark Room*

**JIEXI HE / CHINA**

ISO 100 1/80 F4.0



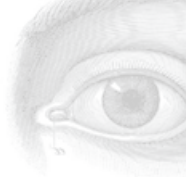

Hebei International Studies University / *Untitled*

3..2..1.. | ..1..2..3

CHINA / **JING WANG**



Academy of Arts, University of Novi Sad / *Finding Peace: A Childhood Memoir*



ISO 100 1/80 F4.0



**JOVANA BERAR / SERBIA**

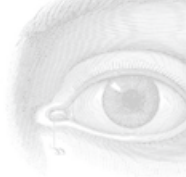

Academy of Arts, University of Novi Sad / *Terminology of feelings*



**Ambedo**

A kind of melancholic trance in which you become completely absorbed in vivid sensory details.

3..2..1.. | ..1..2..3

SERBIA / **JOVANA ĐOKOVIĆ**

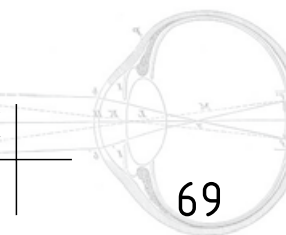



Universidad Nacional de San Martín / Lito



70

**JULIAN CABRAL / ARGENTINA**

Honorable Mention

ISO 100 1/80 F4.0



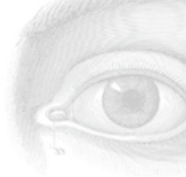

Parsons School of Design / *Body landscape*

3..2..1.. | ..1..2..3

UNITED STATES / **JUNE HUANG**

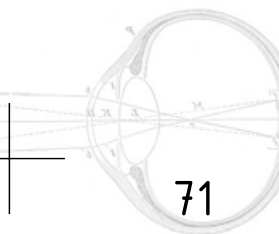





Universidad Veracruzana / Inasible

**KAREN DIAZ / MEXICO**

ISO 100 1/80 F4.0



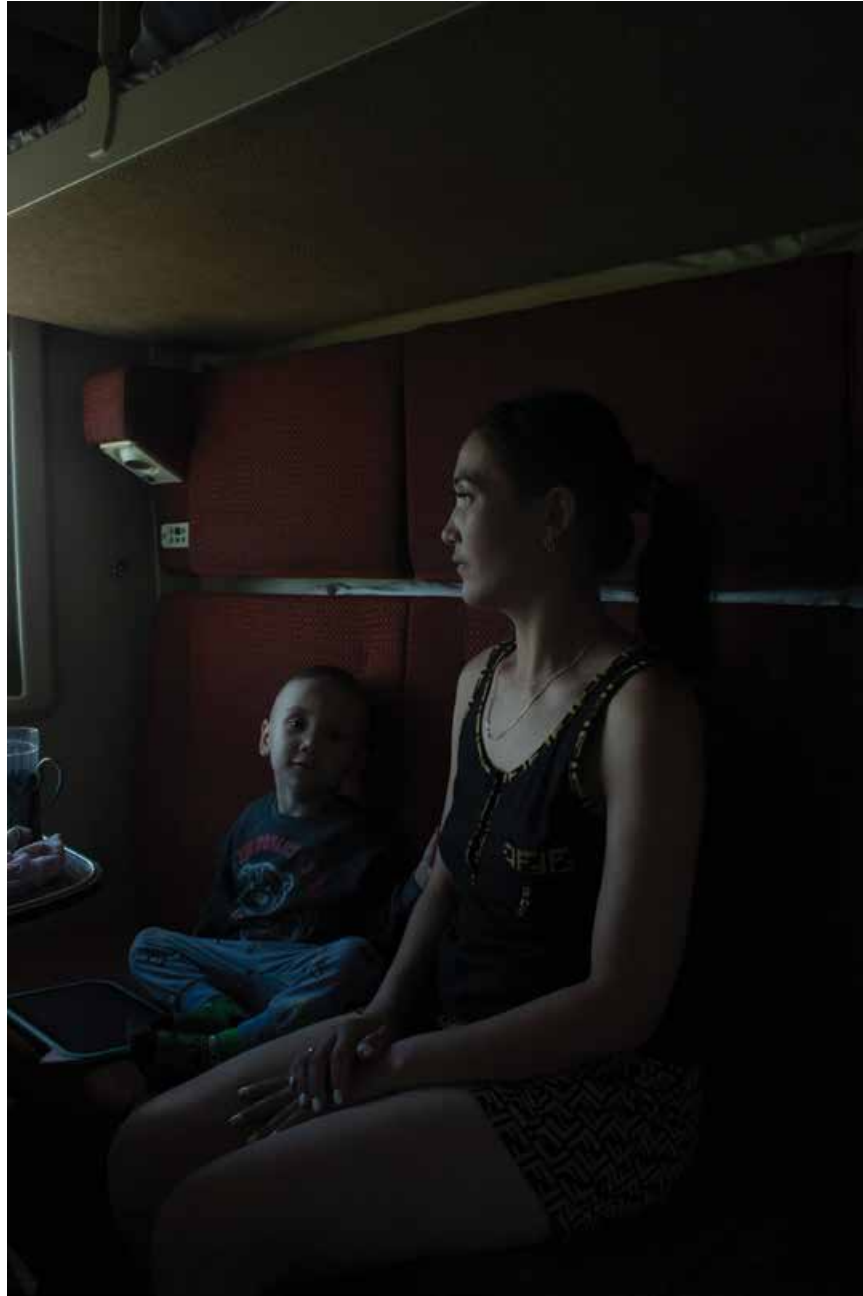
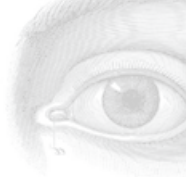

DocDocDoc school of modern photography / *The Ladies-only compartment*

3..2..1.. | ..1..2..3

KAZAKHSTAN / **KARINA OSMANOVA**

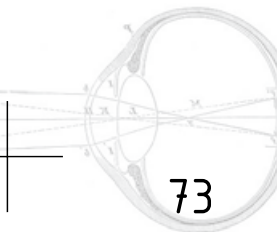



Institute of Creative Photography / Fantastic animals and how to pet them



**KASIA ŚLESIŃSKA / POLAND**

ISO 100 1/80 F4.0



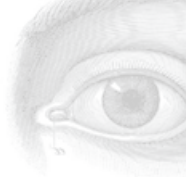

Faculty of dramatic arts / *Empty places*



3..2..1.. | ..1..2..3

SERBIA / **KIŠA RADIĆ**

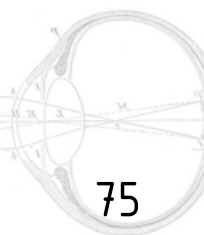

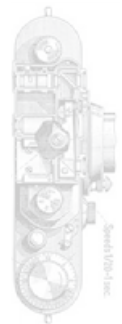

DocDoc school of modern photography / Details



**KONSTANTIN KOLIKOV** / RUSSIA

ISO 100 1/80 F4.0



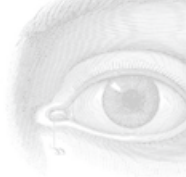

MYPH / *Between Sun and Moon*

3..2..1.. | ..1..2..3

UKRAINE / **KRISTINA MOSIICHUK**

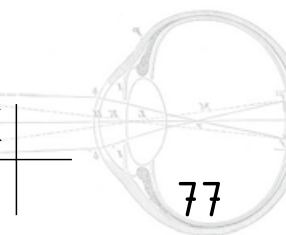



DocDocDoc school of modern photography / Kilelle. Towards home.



ISO 100 1/80 F4.0



**KSENIA MAKSIMOVA** / RUSSIA

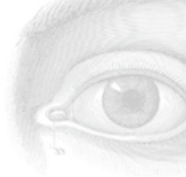

China Conservatory of Music / *The Forgotten Opera Troupe*

3..2..1.. | ..1..2..3



CHINA / **LEON ZHANG**

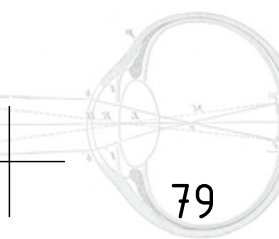





Aalto University / Untitled

**LI TIANJUN** / FINLAND

ISO 100 1/80 F4.0



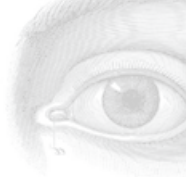

Bielefeld University of Applied Sciences and Arts / *When I was a child*

3..2..1.. | ..1..2..3



GERMANY / **LI ZHANG**

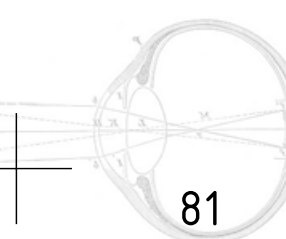



University of West Attica / Focus on Piraeus



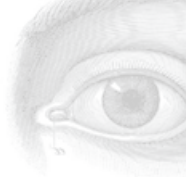

Federal University of Pará / *Panopticon*



3..2..1.. | ..1..2..3

BRAZIL / **LOHANNA OLIVEIRA**

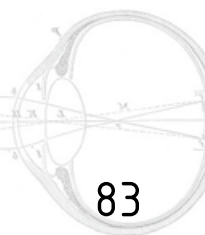



The New School Parsons / I knew I had seen this before

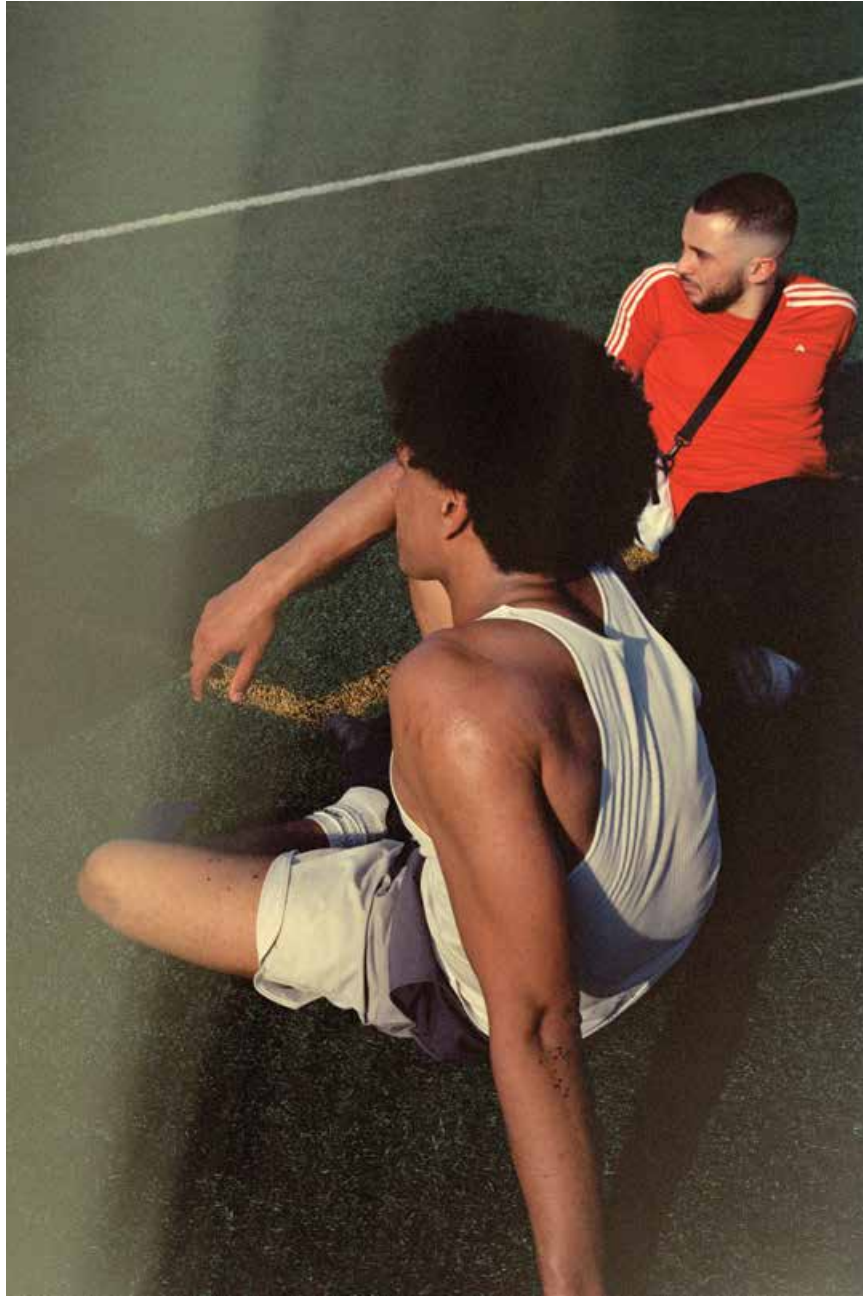

ISO 100 1/80 F4.0



**LUIGI LAGULLI / CANADA**

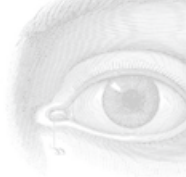

Guilian University / *The Real Glitch*

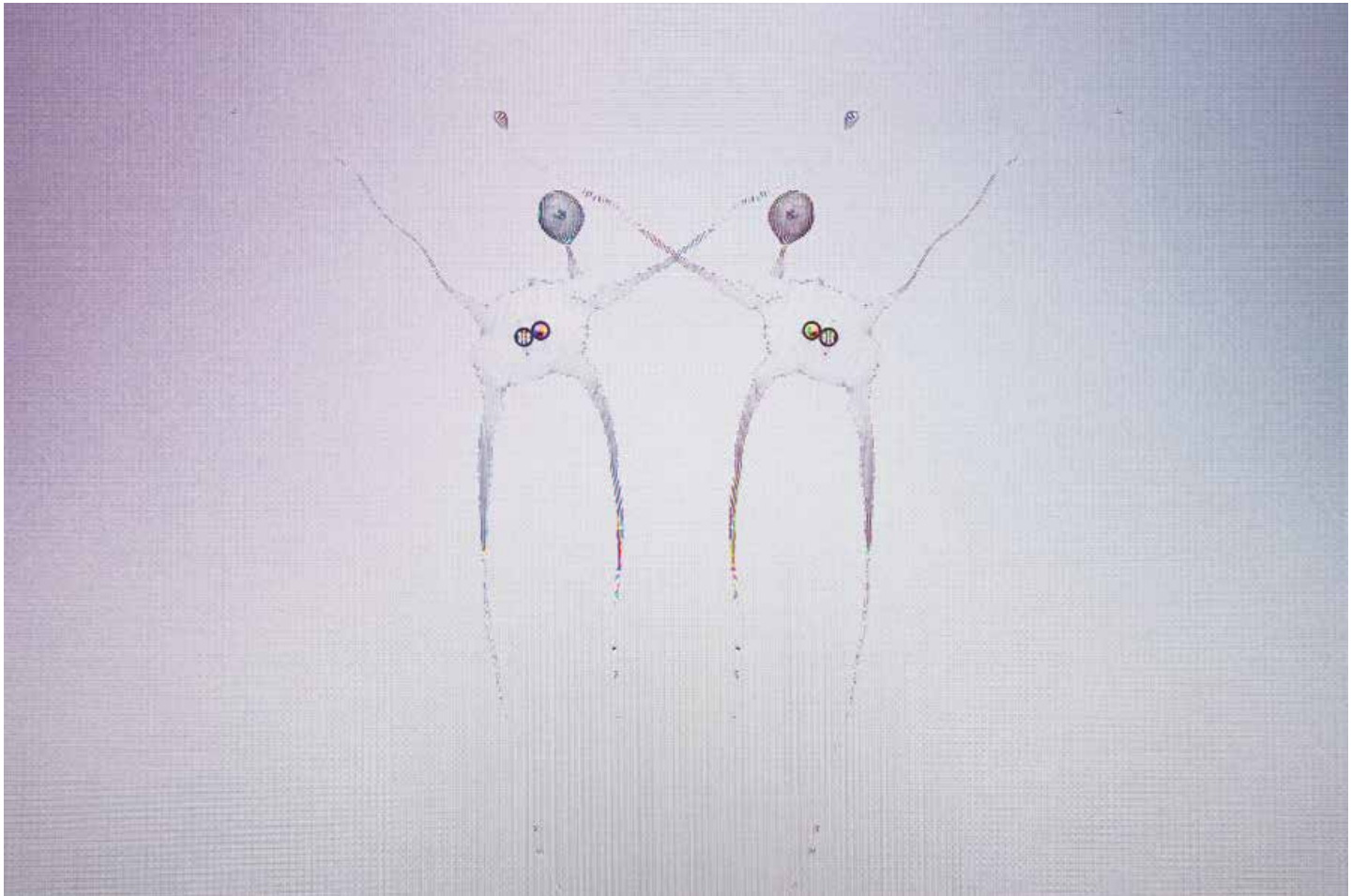

3..2..1.. | ..1..2..3

IRAN / **M.SADEQ ASAD**

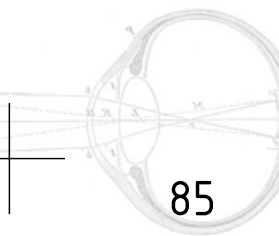



University of Arts and Design from Cluj-Napoca / *Interconnected*

**MARCHIDAN ANDREEA MARIA / ROMANIA**

ISO 100 1/80 F4.0



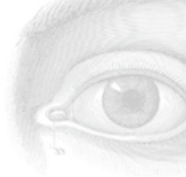

University of West Attica / *Fallen Memories*

GREECE / **MARIA TOULTSINAKI**

3..2..1.. | ..1..2..3

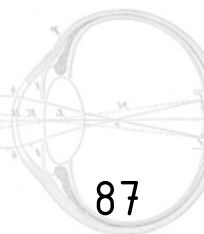



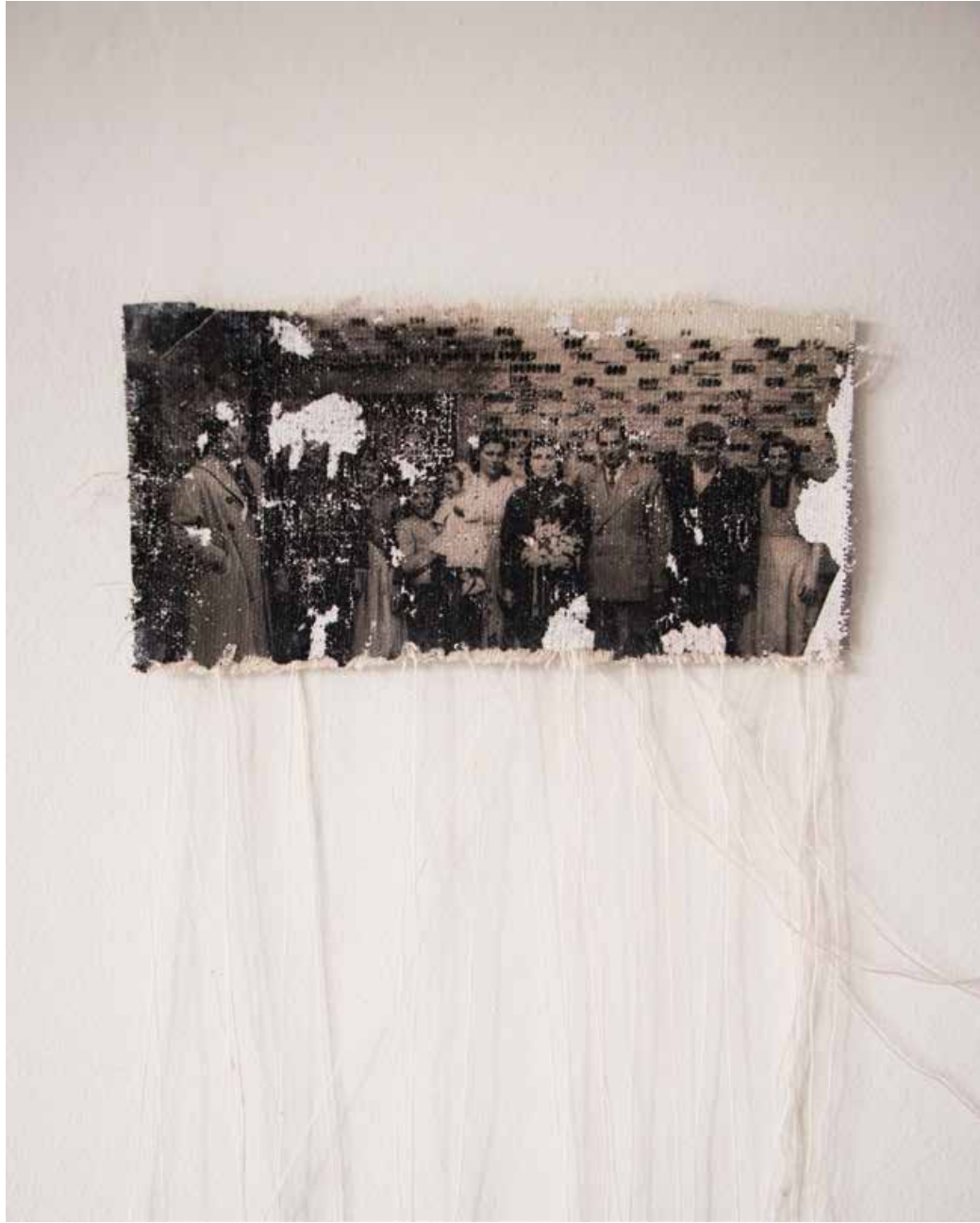

ISO 100 1/80 F4.0

AE-L  
AF-L

**MARINA CAVADI** / SPAIN

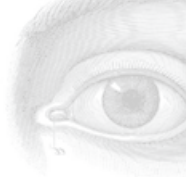

Academy of Fine Arts Sarajevo / *Reflections*

3..2..1.. | ..1..2..3

BOSNIA & HERZEGOVINA / **MARTINA REČ**

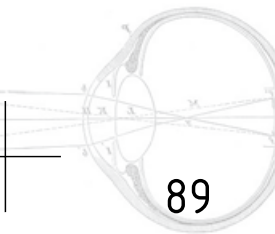



**MAŠA NEDELJKOVIĆ** / SERBIA

ISO 100 1/80 F4.0



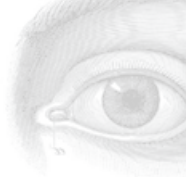

Parsons School of Design / *Body*



3..2..1.. | ..1..2..3

UNITED STATES / **MERCEDES FERNÁNDEZ**

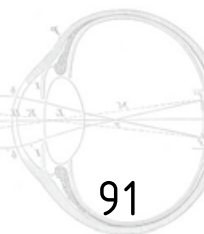

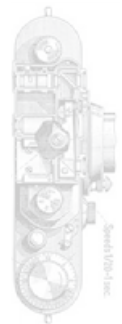

University of Novi Sad, Academy of Arts / Economy 1



**MILANA MILOVANOV** / SERBIA

ISO 100 1/80 F4.0



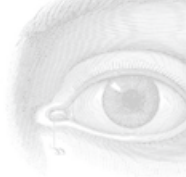

University of Novi Sad, Academy of Arts / *The Veils of the Mind*

3..2..1.. | ..1..2..3

SERBIA / **MILOŠ TOČAKOVIĆ**

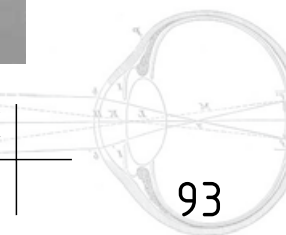



Accademia di Belle Arti Catania / *Un mondo senza peso e senza spazio*



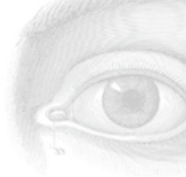

Maturità Linguistica / *Onde Sommerse*



3..2..1.. | ..1..2..3

ITALY / **MIRKO OSTUNI**

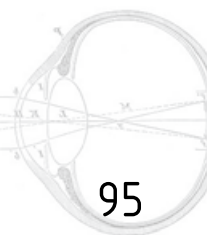





Allameh Amini University / *illusions*

**MOBIN SHAHVAISI / IRAN**

ISO 100 1/80 F4.0



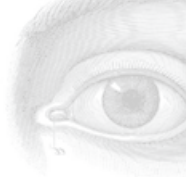

University of the People / Another face of war



3..2..1.. | ..1..2..3

SYRIA / **MOUNEB TAIM**

**1<sup>ST</sup>** PRIZE



DocDoc school of modern photography / Reflection

**NADEZHDA SHTYROVA** / RUSSIA

ISO 100 1/80 F4.0



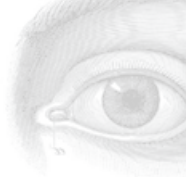

Academy of Fine Arts Mainz / *Untitled*



3..2..1.. | ..1..2..3

GERMANY / **NAZANIN HAFEZ**

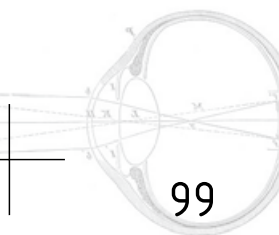



RMIT University Vietnam / *A silent loop*

**NGUYEN MAI PHUONG** / VIETNAM

ISO 100 1/80 F4.0



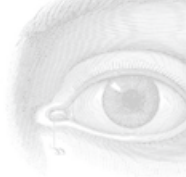

Rodchenko Art School / 34

3..2..1.. | ..1..2..3

RUSSIA / **NIKITA KARASK**

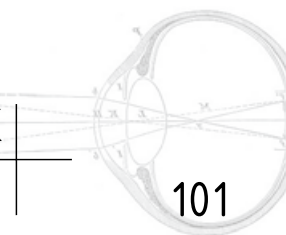



Academy of Fine Arts Sarajevo / Kintsugi: The Beauty of the Imperfect

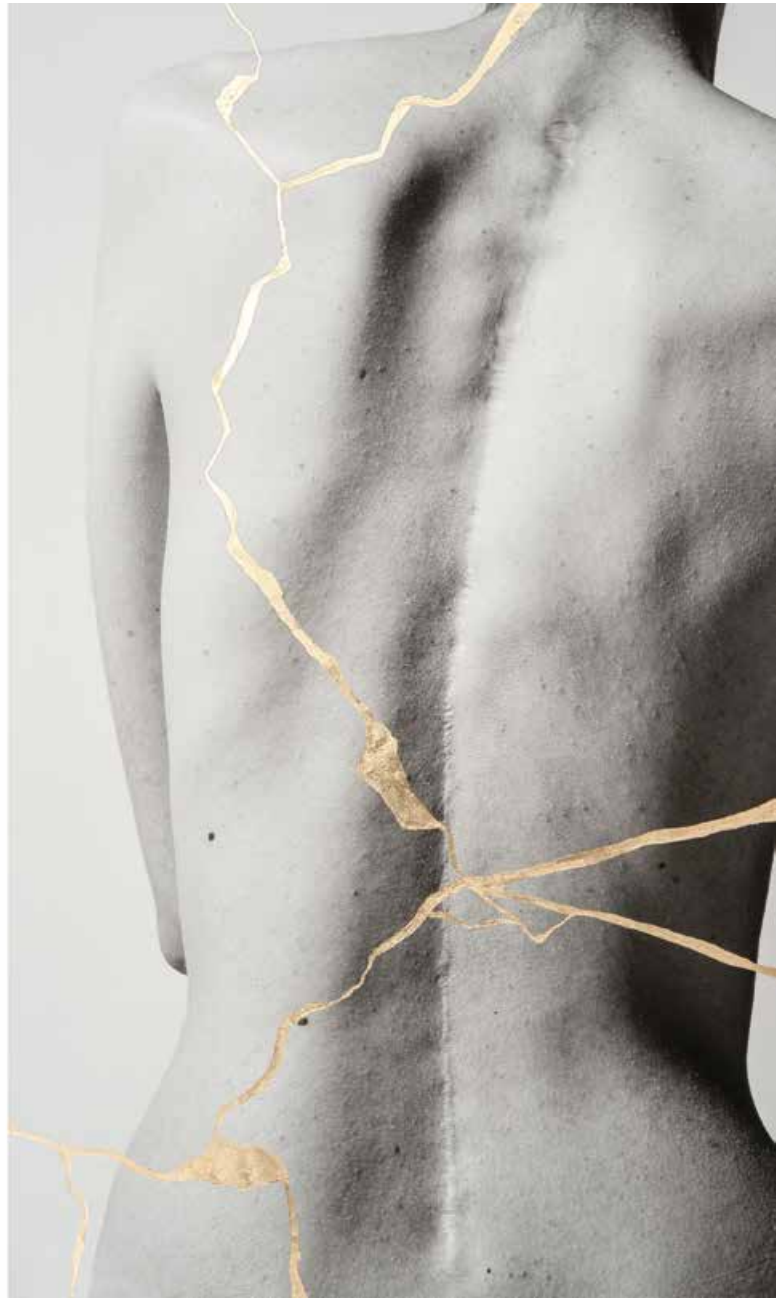

\* Ne postojim na svoj stiljak, jer nije na njemu koje svakodnevno gledam. Ne razmišljam mnogo o njemu, ali mislim da simbolizira nova etapa mog života koja je nastupila nakon operacije. Nikad se bih postidjela da ga nosim. \*

ISO 100 1/80 F4.0

**NORA SALOMÉ BERTHOUD** / BOSNIA & HERZEGOVINA



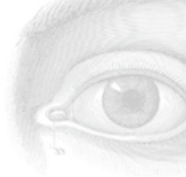

MYPH / Warriors

3..2..1.. | ..1..2..3

UKRAINE / **OKSANA KAMI**

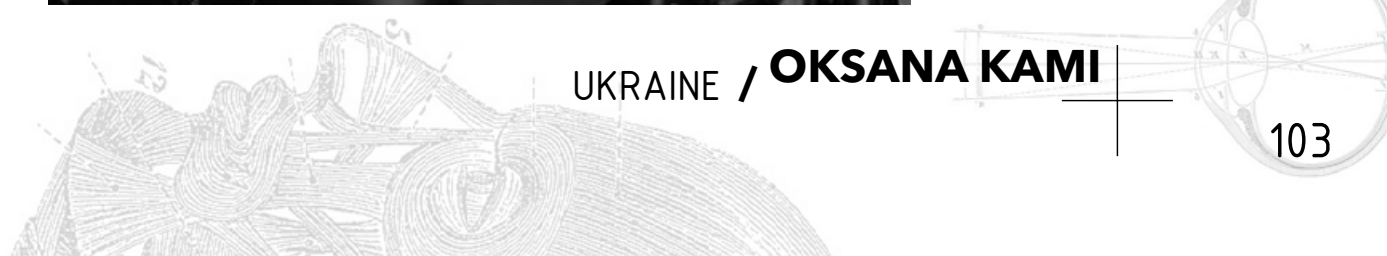





University of conceptual and art photography / *Granny*



ISO 100 1/80 F4.0



**OLENA MOROZOVA / UKRAINE**

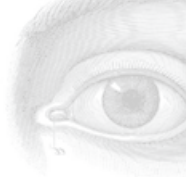

DocDocDoc school of modern photography / *The Most Beautiful Village*



3..2..1.. | ..1..2..3

RUSSIA / **OLESYA TERESHCHENKO**

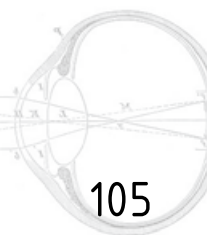

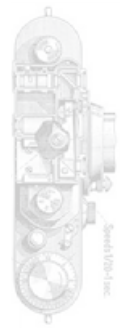

DocDoc school of modern photography / Tick tock



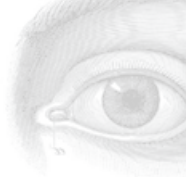

Universidad Veracruzana / Encierro del burro



3..2..1.. | ..1..2..3

MEXICO / **OMAR PÉREZ**

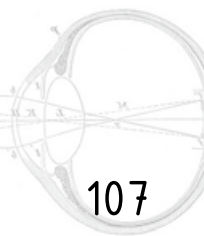



DocDoc school of modern photography / Before Eternity

**OLGA PADALKA** / RUSSIA

ISO 100 1/80 F4.0



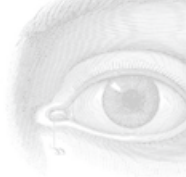

Willem de Kooning Academie / *Anemoia on the shore*

3..2..1.. | ..1..2..3

MOLDOVA / **PAULA GAVRILITA**



DocDocDoc school of modern photography / *Ghost of the Golden Ring*



**PAVEL BASIN** / RUSSIA

ISO 100 1/80 F4.0



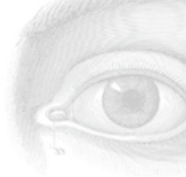

University of Novi Sad, Academy of Arts / Antička Srbija

3..2..1.. | ..1..2..3



SERBIA / **PAVLE SREĆKOV**

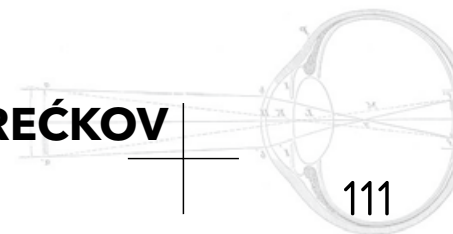





Shariaty vocational and Technical girls collage / Fishing season



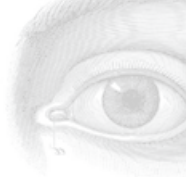

/ Commercial Life

3..2..1.. | ..1..2..3

CHINA / **PENG WANG**

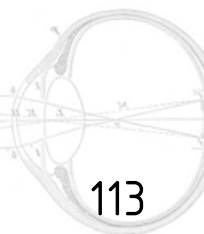



The Silesian University in Opava / Behind the Curtain

**PETER LANČARIČ** / SLOVAKIA

ISO 100 1/80 F4.0



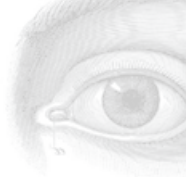

Academy of Fine Arts Sarajevo / *Recyclers*



3..2..1.. | ..1..2..3

BOSNIA & HERZEGOVINA / **PETRA STRBAN**

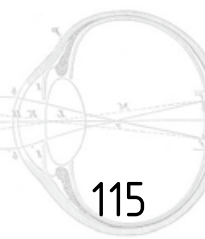



Hochschule Hannover University Of Applied Sciences And Arts / Izkor



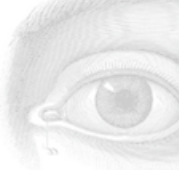

University of West Attica / Notatnik



3..2..1.. | ..1..2..3

GREECE / **RANIA RENTZEPI**

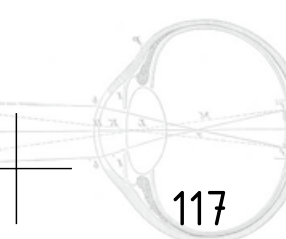



ISO 100 1/80 F4.0



**RUIHAO ZHU / CHINA**

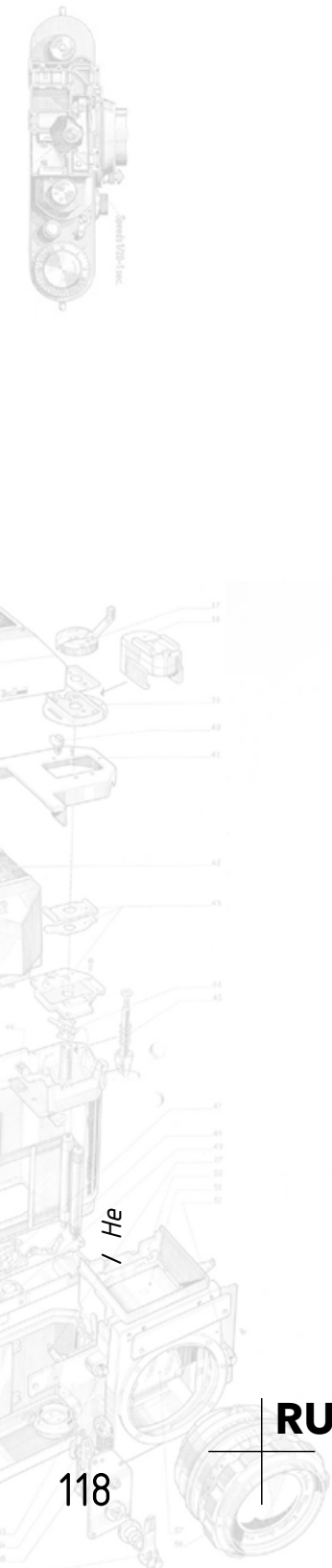

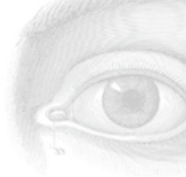

University of Houston / *Precious Time*



3..2..1.. | ..1..2..3

UNITED STATES / **RUTH CAMPOS**

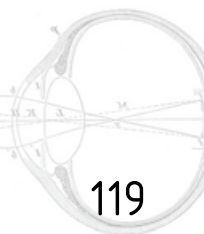



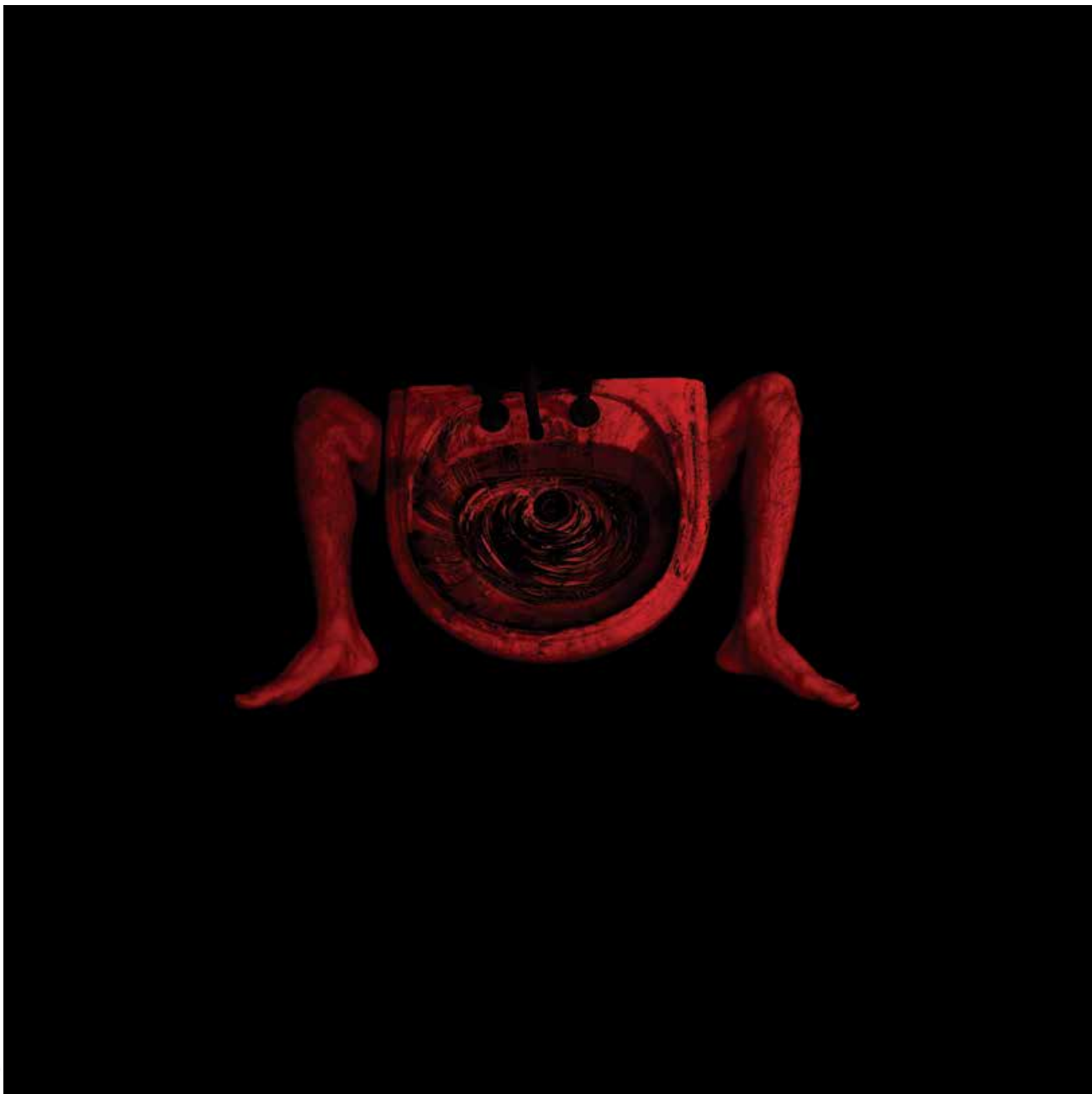

*Guitan University / Evolution in Solitude*

**SADEQ ASAD / IRAN**

ISO 100 1/80 F4.0



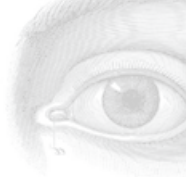

Academy of Fine Arts Sarajevo / Homo Faber

3..2..1.. | ..1..2..3

BOSNIA & HERZEGOVINA / **SAJRA ZULČIĆ**

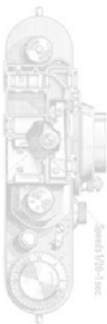

Academy of Fine Arts Sarajevo / In you I see myself?



ISO 100 1/80 F4.0



**SAMIR MRKOVIĆ** / BOSNIA & HERZEGOVINA



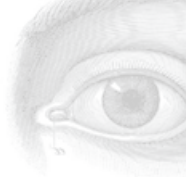

University of Novi Sad, Academy of Arts / *Forgotten Personality Fragments*

3..2..1.. | ..1..2..3

SERBIA / **SANDRA MILANOVIĆ**

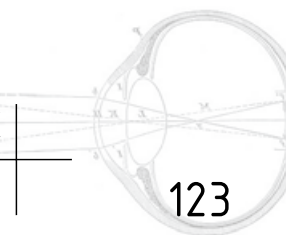

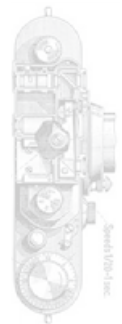

DocDoc school of modern photography / *The scars of the earth*

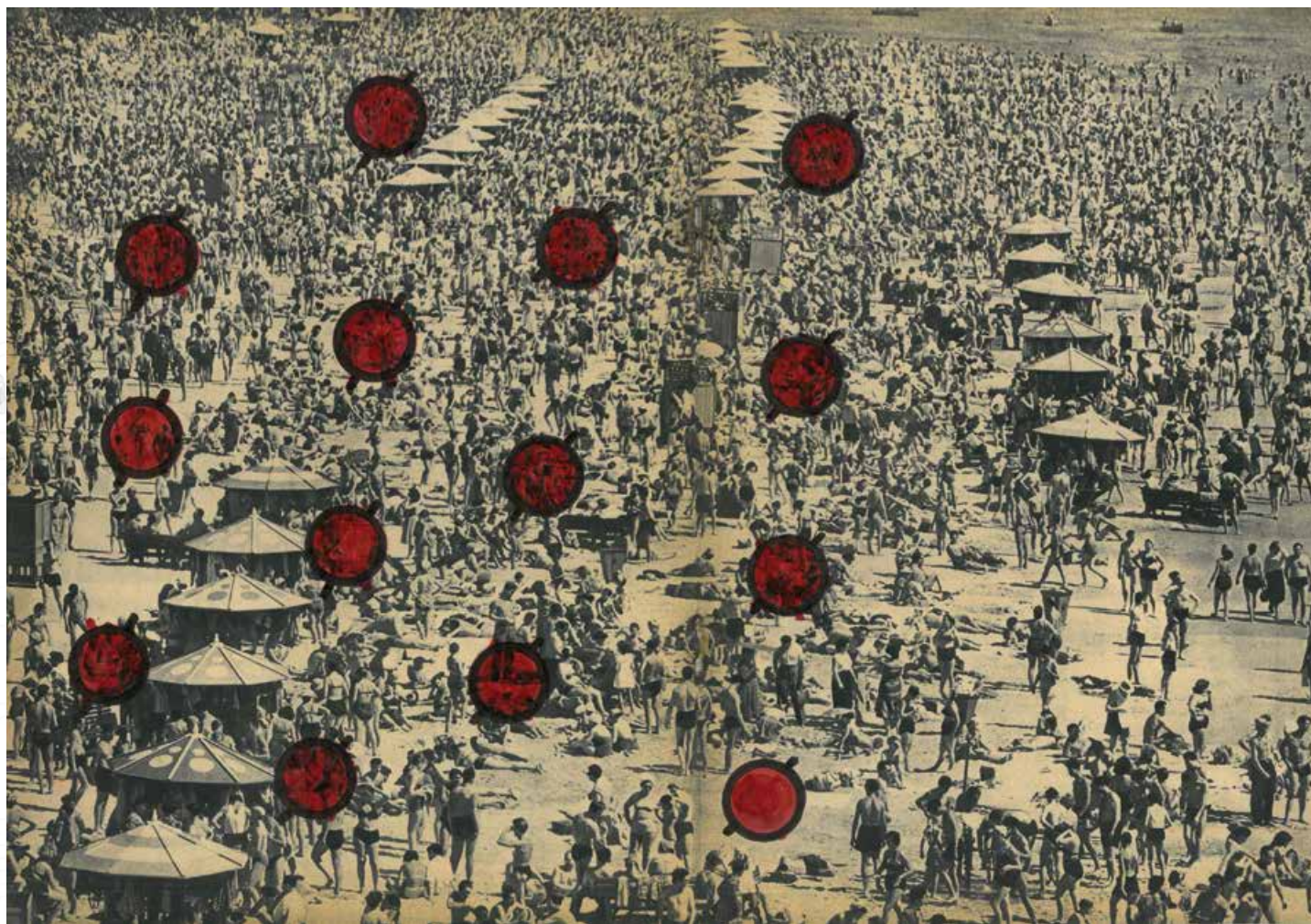

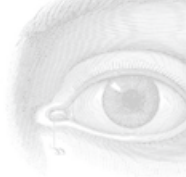

Academy of Fine Arts Sarajevo / *The Land of Cockaigne*

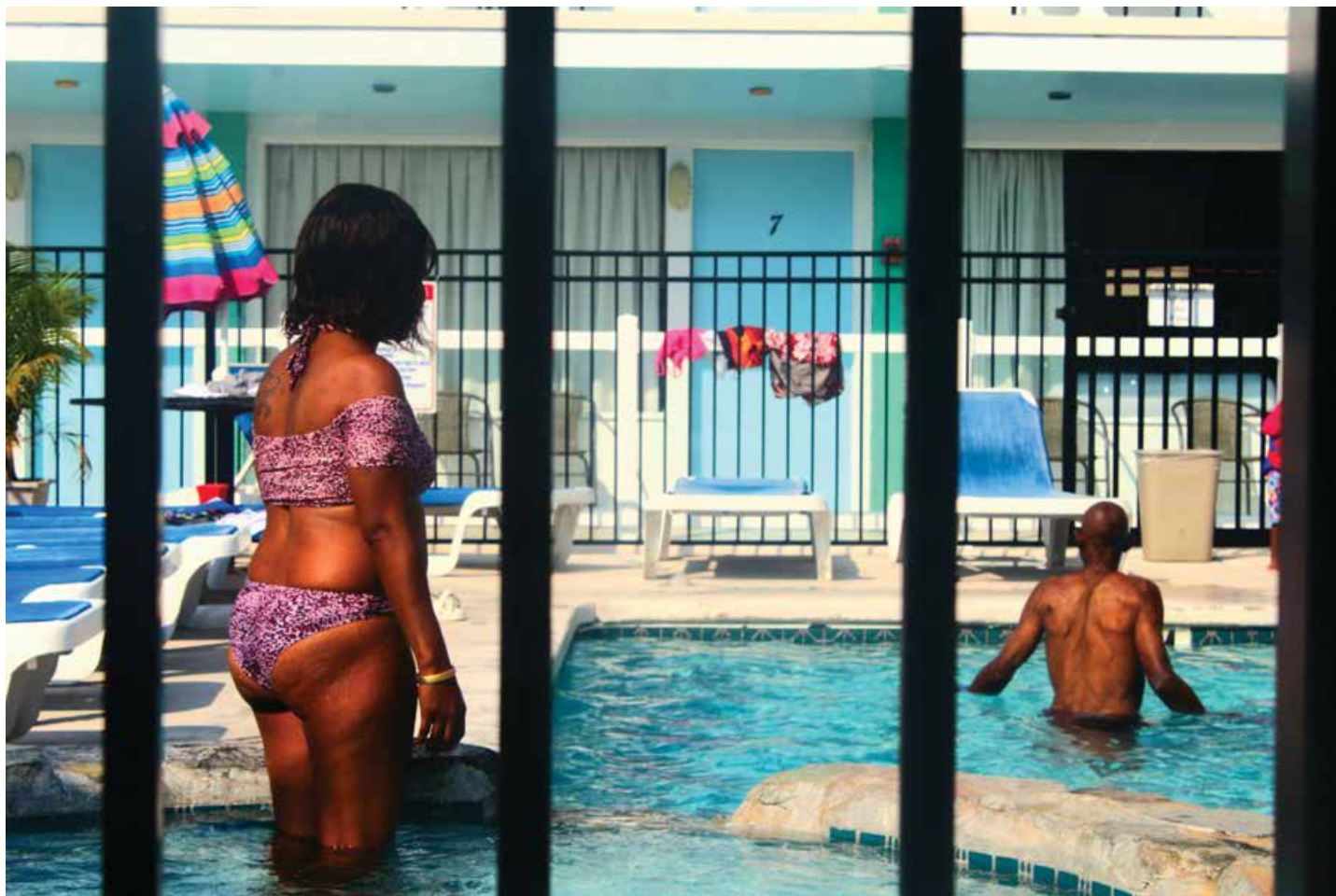

3..2..1.. | ..1..2..3

BOSNIA & HERZEGOVINA / **SERGEJ MAČAR**



Keyi College of Zhejiang Sci-Tech University / *The Cocoon*



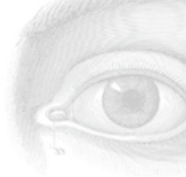

Temple University Philadelphia / *Fruits of Discomfort*

3..2..1.. | ..1..2..3

UNITED STATES / **HENRY SODT**

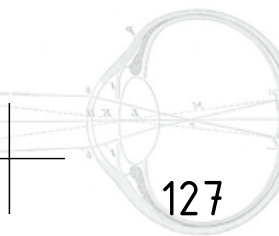





Academy of Fine Arts in Gdansk / *Fragments of Self*



ISO 100 1/80 F4.0



**SOFIIA LUPUL** / UKRAINE

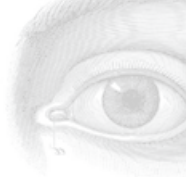

EASD Mestre Mateo / *It's a quiet starry place*

3..2..1.. | ..1..2..3

SPAIN / **SOFÍA TABOADA**

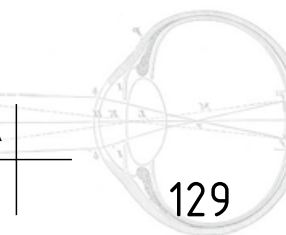



University of Novi Sad, Academy of Arts / Lords of the Valley

**STEFAN STEFANOVSKI / SERBIA**

ISO 100 1/80 F4.0



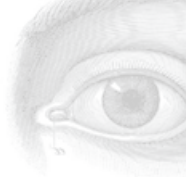

University of Gloucestershire / Mesagne Archive

3..2..1.. | ..1..2..3

UNITED KINGDOM / **STEFANIA DISTANTE**

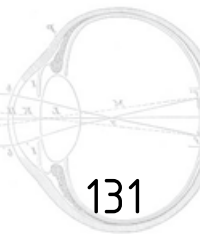



Academy of Dramatic Arts / Links

**STELLA VLASNOVIĆ** / CROATIA

ISO 100 1/80 F4.0



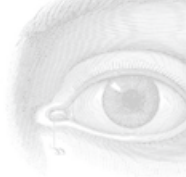

Communication University of China /  
*We will meet again when the next summer is ending*

3..2..1.. | ..1..2..3

CHINA / **SUNNY SUN**

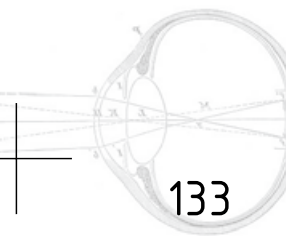



Faculty of Technical Sciences / *The freedom of darkness*



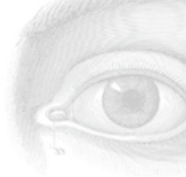

University of West Attica / *Untitled*



3..2..1.. | ..1..2..3

GREECE / **THALEIA THEODORAKOPOULOU**

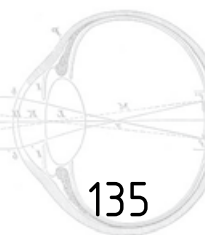





Universitas Pelita Harapan / Model Photography: Legend Singers



ISO 100 1/80 F4.0



**TIARA KIATAMA / INDONESIA**

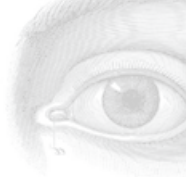



DocDocDoc school of modern photography / Those who left



ISO 100 1/80 F4.0



**ULIANA BELIAEVA** / RUSSIA

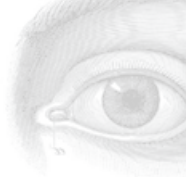

Academy of Fine Arts Sarajevo / *Frame in Frame*



3..2..1.. | ..1..2..3

BOSNIA & HERZEGOVINA / **UNA MAZRAK**



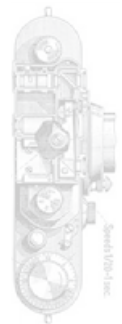

Academy of Fine Arts / Genius Loci

**URSZULA WERESZCZYŃSKA / POLAND**

ISO 100 1/80 F4.0



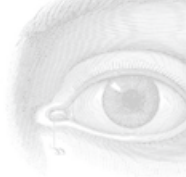

MYPH / At the forest edge

3..2..1.. | ..1..2..3

UKRAINE / VALERIIA MIRHORODCHENKO

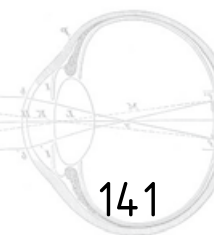



ISO 100 1/80 F4.0



**VLADIMIR JANIĆ / SERBIA**

Special prize awarded by non-government organization "Vojvodina OK"  
for the best student project in the national category

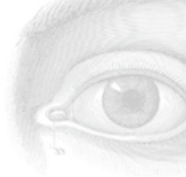

DocDoc school of modern photography / *Baby teeth, stay with me*

3..2..1.. | ..1..2..3

RUSSIA / **VOVA LEBEDEV**



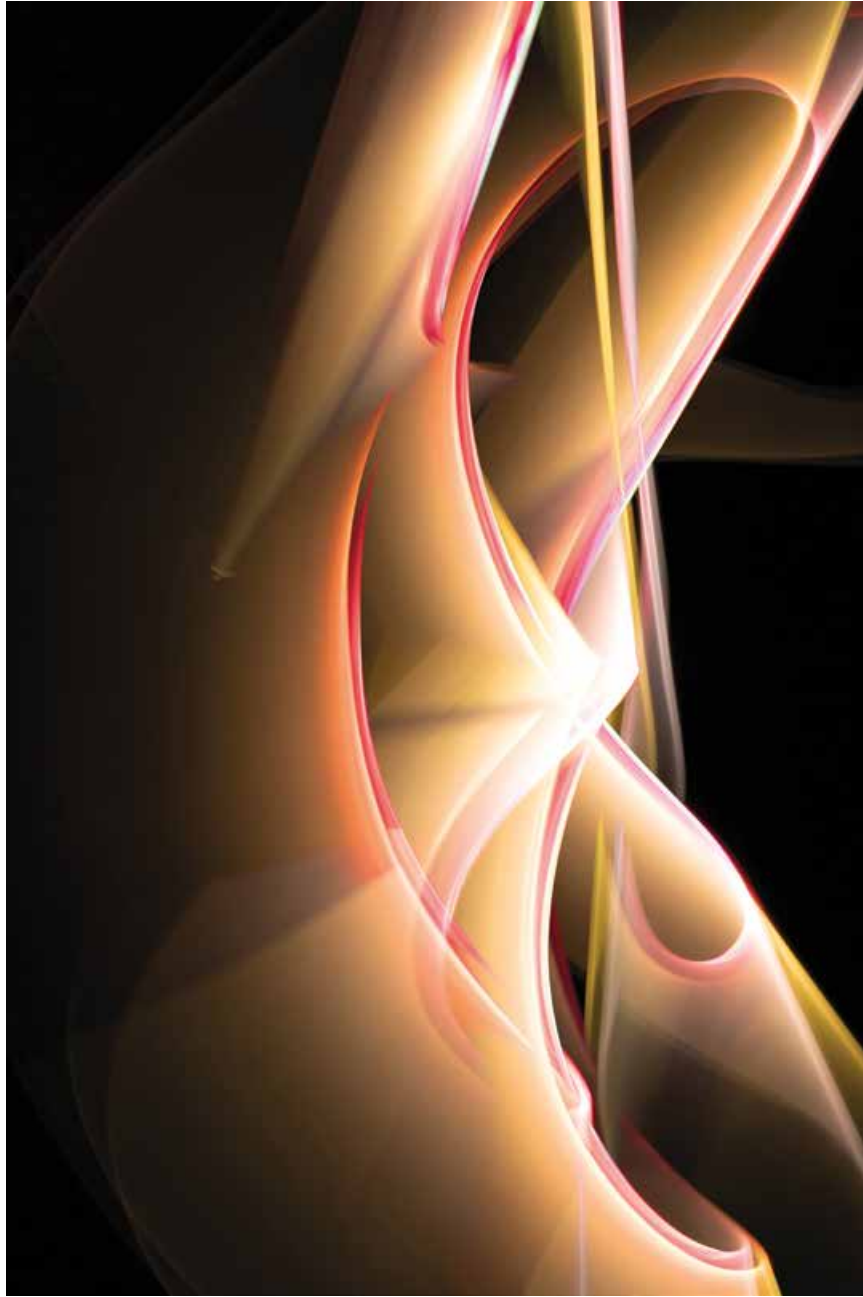

ISO 100 1/80 F4.0



**XIN YU LOKE** / MALAYSIA



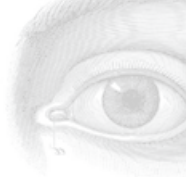

Qufu Normal University / The Disappearing Chu Opera



3..2..1.. | ..1..2..3

CHINA / XING SHU WANG



Donghua University / 1980s

**XINTONG ZHANG / CHINA**

ISO 100 1/80 F4.0



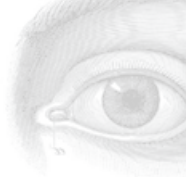

University of Electronic Science and Technology of China / *Strange homesickness*

3..2..1.. | ..1..2..3



CHINA / **YIDAN FANG**

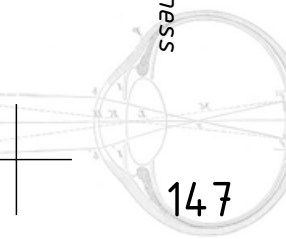

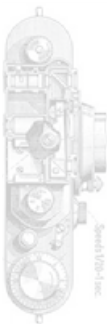

Zhejiang University / Remember

**YILAN CUI / CHINA**

ISO 100 1/80 F4.0



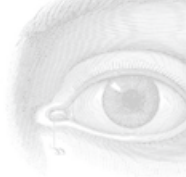

Central Academy of Fine Arts / Hometown



3..2..1.. | ..1..2..3

CHINA / **YIXUAN LING**

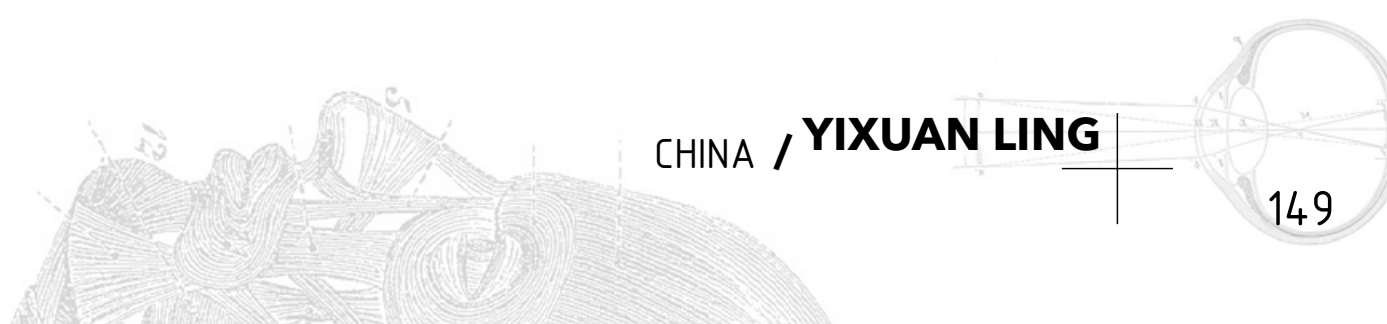



The New School / Food / Ate in America

**YUHAN PAN** / UNITED STATES

ISO 100 1/80 F4.0



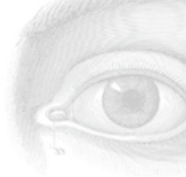

Central China Normal University / *Goblin Mode*

3..2..1.. | ..1..2..3



CHINA / **ZIYI LIU**

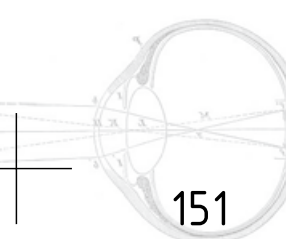





University of West Attica / In Transition

**ZOI KOTSAMPASI / GREECE**

ISO 100 1/80 F4.0



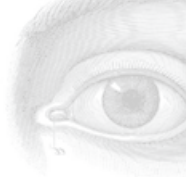

Academy of Arts in Novi Sad / Masks



3..2..1.. | ..1..2..3

SERBIA / **MILJAN SEKULIĆ**

153



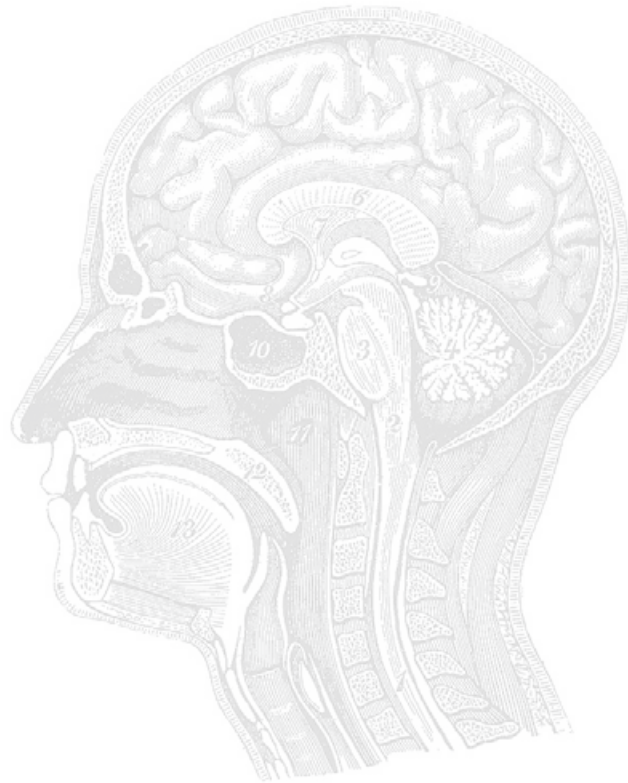

3..2..1.. | ..1..2..3

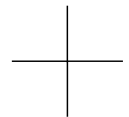

CIP - Каталогизација у публикацији  
Библиотека Матице српске, Нови Сад

77.04-057.875(497.113 Novi Sad)"2023"(083.824)

**СВЕТСКИ бијенале студентске фотографије (9 ; 2023 ; Нови Сад)**

9. svetski bijenale studentske fotografije = 9th World Biennial of Student Photography : Univerzitet u Novom Sadu, Akademija umetnosti, Novi Sad, Vojvodina, Srbija, decembar 2023. = University of Novi Sad Academy of Arts / [urednik, editor Ivan Karlavariš]. - Novi Sad : Akademija umetnosti : Vojvodina OK, 2023 (Petrovaradin : Simbol). - 152 str. : ilustr. ; 23 cm

Uporedo srp. tekst i engl. prevod. - Tiraž 750.

ISBN 978-86-81666-71-5

а) Светски бијенале студентске фотографије (9 ; 2023 ; Нови Сад) --  
Изложбени каталози

COBISS.SR-ID 131910921

